

TECHNA-CHECK[®]
TC101/102 Tool Monitoring System

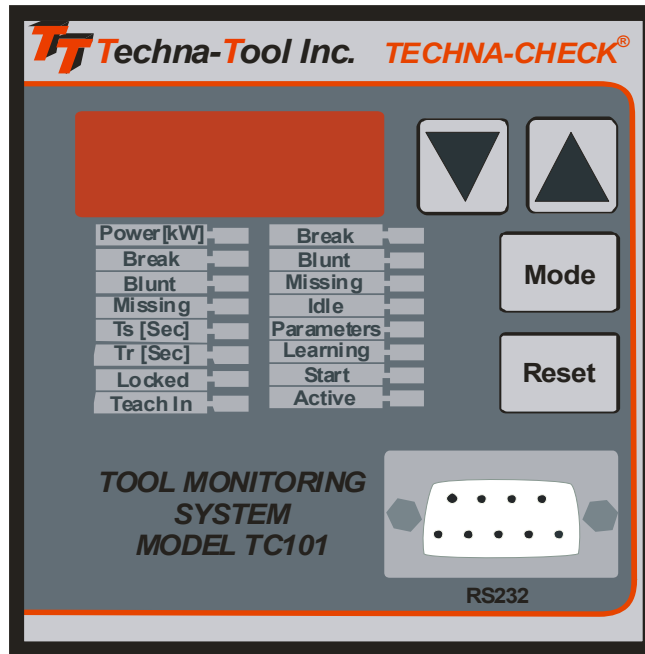

Tool Monitoring System

Technical Documentation

Software Revision 1.0

Released: May, 2003

© Copyright 2003, Techna-Tool Inc., Hartland, Wisconsin, USA.

The information in this document is subject to change without notice.

TECHNA-CHECK[®] is a registered trademark of Techna-Tool Inc.

Table Of Contents:

1.	The Concept	4
2.	Key Benefits	4
3.	Function	5
	3.1 General	5
	3.2 Learn Signal	6
	3.2.1 Learn Cycle Initiation - Machine Controlled	6
	3.2.2 Learn Cycle Initiation - Face Plate	6
	3.2.3 Learn Cycle Initiation - TOOLMON	6
	3.3 Fault Signals and Resetting of Faults	6
	3.4 Analog Zoom Function	7
	3.5 Missing Tool Supervision	8
	3.5.1 Missing Tool - Absolute Mode	8
	3.5.2 Missing Tool - Learn Work Mode	9
	3.6 Tool Break Supervision	10
	3.6.1 Break Mode Selection	10
	3.6.2 Tool Break - Absolute Peak Mode	10
	3.6.3 Tool Break - Learn Peak Mode	11
	3.6.4 Tool Break - Absolute Peak Curve	12
	3.7 Blunt Tool Supervision	13
	3.7.1 Blunt Mode Selection	13
	3.7.2 Blunt Tool - Peak Mode	14
	3.7.3 Blunt Tool - Learn Peak Mode	15
	3.7.4 Blunt Tool - Learn Work Mode	16
	3.7.5 Blunt On Good Parts Counting	17
	3.8 Idle Power Monitoring	18
	3.9 TC102 - Touch Point Limit	19
4.	Programming and display	20
	4.1 Display	20
	4.2 Locking and Unlocking	20
	4.3 Primary Monitoring Limits and Timers	20
	4.4 Parameter Mode	21
5.	Installation Notes	22
	5.1 Mechanical Mounting	22
	5.2 Electrical Connection	22
	5.2.1 Power	22
	5.2.2 Control Inputs	22
	5.2.3 Control Outputs	22
	5.3 Wiring of the PWM125 or the PWM350 Module	22
	5.3.1 Current Measurement Range	22
	5.4 Interfacing TC101 to PWM125	23
	5.5 Interfacing TC101 to PWM350	24
	5.6 Interfacing TC102 to Drive with 0—10 V Output	25
	5.7 Networking and Communicating TC101 TC102	26
6.	Ratings and Specifications	27
	6.1 Techna Check® TC101	27
	6.1.1 Mechanical	27
	6.1.2 Electrical	27
	6.2 Techna Check® PWM125	27
	6.2.1 Mechanical	27
	6.2.2 Electrical	27
	6.3 Techna Check® PWM350	27
	6.3.1 Mechanical	27
	6.3.2 Electrical	27

1. The Concept

The **Techna Check**® TC101 in combination with an external measurement transducer PWM125 or PWM325A measures and displays electrical power consumption (kW). The power calculated is true electrical power, including AC power factor, given by the formula:

$$P = \sqrt{3} \times U \times I \times \cos\Phi$$

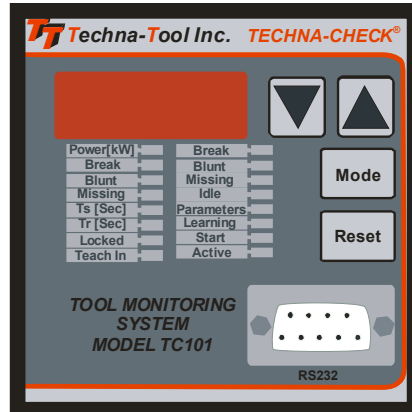

The TC101 has been exclusively developed for the **supervision of cutting tools on single spindle automatic machine tools. It is capable of detecting missing, blunt, and broken or damaged tooling.** The TC101 measures the electrical power consumption of the spindle motor. A blunt (or worn) tool needs more energy to complete a machining cycle, and when a tool breaks a short energy peak or spike is created. If no tool is present, the power consumption drops back to the idle power of the spindle.

The TC101 is designed to monitor motor power in the primary or secondary of a variable frequency motor drive

2. Key Benefits

Improved part quality

The detection of missing or broken tools helps insure that the proper machining is being performed. Detection of tool wear and damage can help improve surface finish and tolerances.

Maximized tool life

By detecting for tool wear and damage, expensive tooling can be changed before the damage gets too severe. This detection also reduces dependence on hit or miss part counting schemes.

Protection of spindle and feed mechanism

By detecting catastrophic tool failures, the **Techna Check**® TC101 system can prevent serious damage to your head and feed mechanisms, not just at the station being monitored, but at downstream stations where "chain reaction" effects can occur.

Improved up time

By creating the process improvements listed above, **Techna Check**® TC101 system keeps your machine running longer.

Easy installation

No mechanical modification of the machinery is necessary. The entire system mounts easily in your electrical cabinet.

3. Function

3.1 General

The figure below shows typical power consumption on a machine spindle during a machining cycle. The first power peak, which is caused by a change in motor speed or a motor start, is not monitored at all. Only the portion of the cut where the spindle speed is constant and the tool is actually in cut is monitored by the unit. When the machine head begins to move towards the part, a "Start" Signal is generated by the machine, which tells the **Techna Check**[®] unit that a new cycle is beginning. When the unit receives the start signal, the green Start LED is illuminated, and the user-defined **Start Delay, T_s** , is activated.

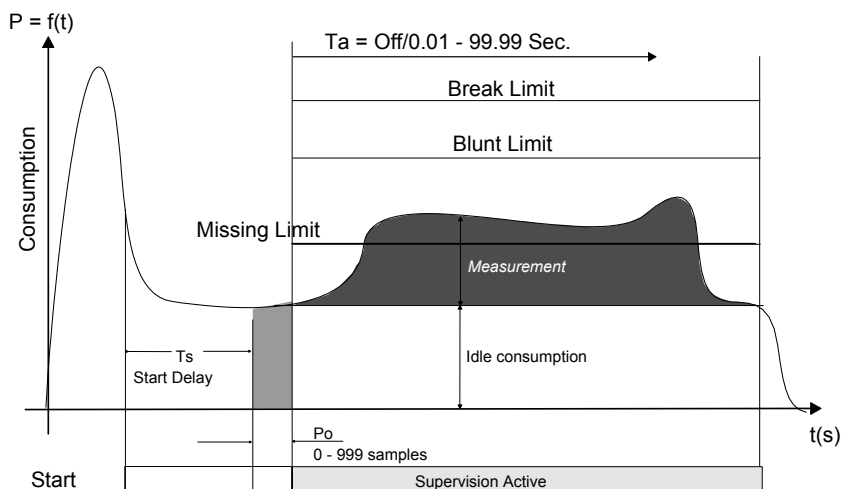

When the start delay ends, the unit initiates the idle power measurement. It is very important to measure the idle power **before** the tool begins cutting the part. The **idle power consumption, P_o** , is the portion of work done by the machine not going into the cut. Idle power consumption will vary normally during the course of the day due to such factors as friction, temperature, oil and grease viscosity, etc. The idle power is calculated as an average of a number of power measurements taken over a user-defined number of half electrical cycles (in North America, there are 60 electrical cycles per second). The number of samples (half electrical cycles) used to calculate the idle power is user set as the value of **Po Averaging** (parameter #2). Minimum and maximum values of Idle Power, P_{oMin} and P_{oMax} (parameters #7 and #6) may be set.

After the idle power measurement, the tool monitoring becomes active, and the green Active LED is illuminated. The duration of monitoring may be limited through the use of the monitoring timers, **T_a and T_w** , in order to avoid monitoring undesired events, such as motor speed changes. In many cases, these timers may be turned off, allowing monitoring for as long as the start signal is present. The **Techna Check**[®] unit includes a user programmable **Power Averaging** (parameter #1) feature, which sets the number of individual power measurements which are averaged into one calculated value (again, the number of power measurements is related to the frequency of the supply power). This averaging can be used to "smooth" very noisy electrical signals, but it should be set as low as possible in order not to filter out very short duration power surges caused by tooling problems. **Techna Check**[®] system includes a unique **Analog Zoom Function**, which greatly improves the monitoring of small tools. Refer to the section on "Analog Zoom Function" for details.

3.2 Learn Signal

For each type of monitoring (Missing, Break, and Blunt), there are one or more "Learn" modes available. The Learn modes allow the monitoring to change to take into account variations in tool grind from one tool to the next. In most applications, when using Learn modes, a Learn cycle should be initiated whenever the tool is changed. A Learn cycle may be initiated in three ways, as described below. It should be noted that during a Learn cycle, only Idle Power monitoring is taking place.

3.2.1 Learn Cycle Initiation -- Machine Controlled

A Learn cycle may be initiated by the machine controller. If the Start signal is made active while the Reset signal is being held active, the cycle will be a Learn cycle. If an Idle Power fault would occur during the Learn cycle, the reset signal must be taken low, then brought back high again to reset the fault.

3.2.2 Learn Cycle Initiation -- Face Plate

A Learn cycle may be initiated from the keyboard on the face plate of the unit. With the system unlocked, the MODE key is pressed until Teach-In mode is selected. The display shows "OFF". To initiate the Learn cycle, one of the arrow keys is pressed, causing the display to show "ON". The next cycle will be a Learn cycle.

3.2.3 Learn Cycle Initiation -- TOOLMON

A Learn cycle may be initiated from the TOOLMON software package by pressing the appropriate function key.

3.3 Fault Signals and Resetting of Faults

All faults generated by the **Techna Check**[®] system are signaled to the machine controller by normally closed dry contact relays (refer to the section on "Electrical Connection"). The Tool Break and Tool Missing faults share a common relay. It is typical that the machine will be programmed to stop its present cycle immediately and retract the machine head on detection of a Tool Missing or Tool Break condition. The Blunt Tool fault is signaled by a second relay. It is typical that the machine will be programmed to finish the current cycle before stopping the machine on a Blunt Tool fault.

All faults may be reset by using the RESET button located on the front panel of the unit, or through the use of the external Reset input (refer to the section on "Electrical Connection"). The fault relays will remain in their active (open) condition until a reset is received.

3.4 Analog Zoom Function

Prior to setting the monitoring parameters, it is desirable to set up the **Analog Zoom Function** parameters. The Analog Zoom Function enables the **Techna Check**[®] system to monitor even very small tools by "focusing" the unit's full analog to digital conversion resolution into a narrow band of power consumption. To set the parameters, it is most helpful to use the TOOLMON support software. Note that the Analog Zoom Function should be set up prior to setting monitoring parameters, as the monitoring parameters will be "re-scaled" if changes are made to the Analog Zoom.

The **current measurement range** must first be set. Setting the current measurement range depends on the particular measurement transducer applied in the application. Transducer wiring is shown in the end of this manual. Once the current measurement range has been set, then any large idle powers may be subtracted from the display by adjusting P1Min so that the idle is only 5% to 10% of the full load. P1Max may then be adjusted so that the cutting torque is a rise of 10% to 20% above idle.

The figure below shows a hypothetical application to highlight the power of the Analog Zoom Function. In this application, a 380 VAC, three phase motor is being monitored. If the Current Range is set to 10 A, then 100% power is equivalent to 6.58 kW. If a small tool with a high spindle speed is being used, it is entirely possible that the idle power may be as high as 50% of the scale, while the cutting torque may only rise 2% or 3%. In order to maximize the ability to monitor this application, P1Min is "zoomed" to 50%, while P1Max is "zoomed" to 60%. The entire resolution of the unit is now concentrated in a 10% band. The unit is now only monitoring between 3.29 kW and 3.95 kW. The cutting torque will appear to be 10 times bigger.

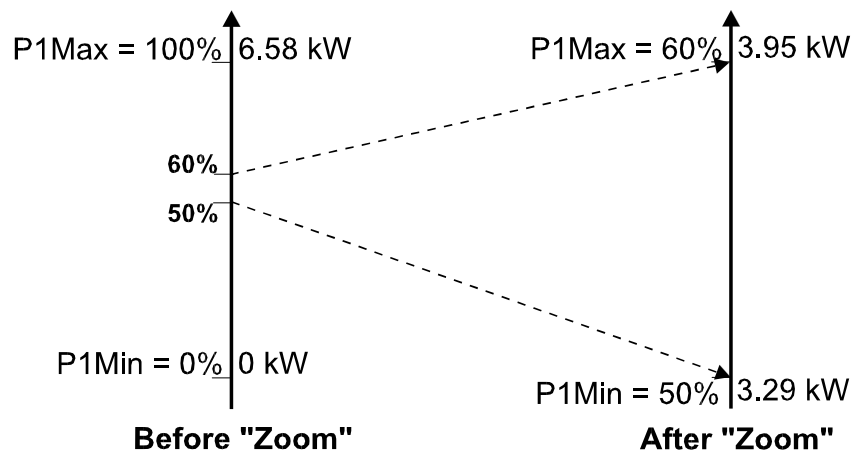

3.5 Missing Tool Supervision

3.5.1 Missing Tool -- Absolute Mode

The figure below shows how the missing tool detection, absolute mode, is set up relative to a typical machining cycle. The **Missing Mode** defines the type of **Missing Tool Limit**, which will be set. In the **Absolute mode**, the Missing Tool Limit is a user-defined absolute torque rise above idle. The power consumption during the machining cycle must remain above the limit for a cumulative time longer than the **Missing Delay**, **Trm**. (Note that the cumulative nature of this measurement means that brief power dips below the Missing Limit will not cause a fault as long as the TOTAL amount of time spent above the Missing Limit is greater than the Missing Delay.) The red Missing LED is lit whenever the power is greater than the Missing Limit, until the Missing Delay has been satisfied. In the event of a missing tool fault, the red Missing LED will flash. Missing Tool supervision remains active for the duration of **Tw**, if **Tw** is enabled. If **Tw** is turned off, Missing Tool supervision remains active the entire time the start signal is present, following the **Start Delay** and the idle power measurement.

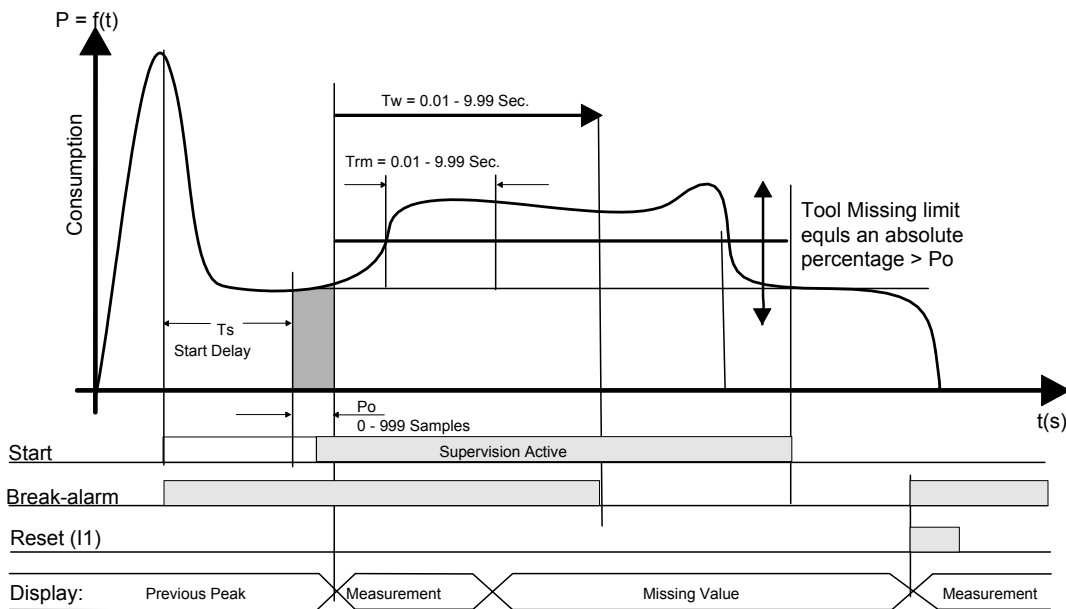

In determining appropriate values for the Missing Limit and Missing Delay, more aggressive monitoring can be achieved with higher Missing Limits and longer Missing Delays (in other words, for a good cycle, the power must stay higher longer). However, setting these parameters too aggressively can result in more frequent nuisance trips. A good compromise and starting point for adjustment seems to be to set the Missing Limit fairly low, around 3 - 5 % (since if the tool is missing, there will be NO rise above idle), and to set a Missing Delay of about 3/4 of the total machining time. Better results seem to be achieved by leaving the Missing Limit low, and tuning out nuisance trips by adjusting the Missing Delay.

3.5.2 Missing Tool -- Learn Work Mode

The figure shows how the missing tool detection, Learn Work mode, is set up relative to a typical machining cycle. In the **Learn Work mode**, the Missing Tool Limit is a user-defined relative percentage of the work calculated during the Learn cycle. If the work calculated during a cycle does not exceed this percentage of the learned work, then a Missing alarm is generated. In the event of a missing tool fault, the red Missing LED will flash. Missing Tool supervision remains active for the duration of **Tw**, if **Tw** is enabled. If **Tw** is turned off, Missing Tool supervision remains active the entire time the start signal is present, following the **Start Delay** and the idle power measurement.

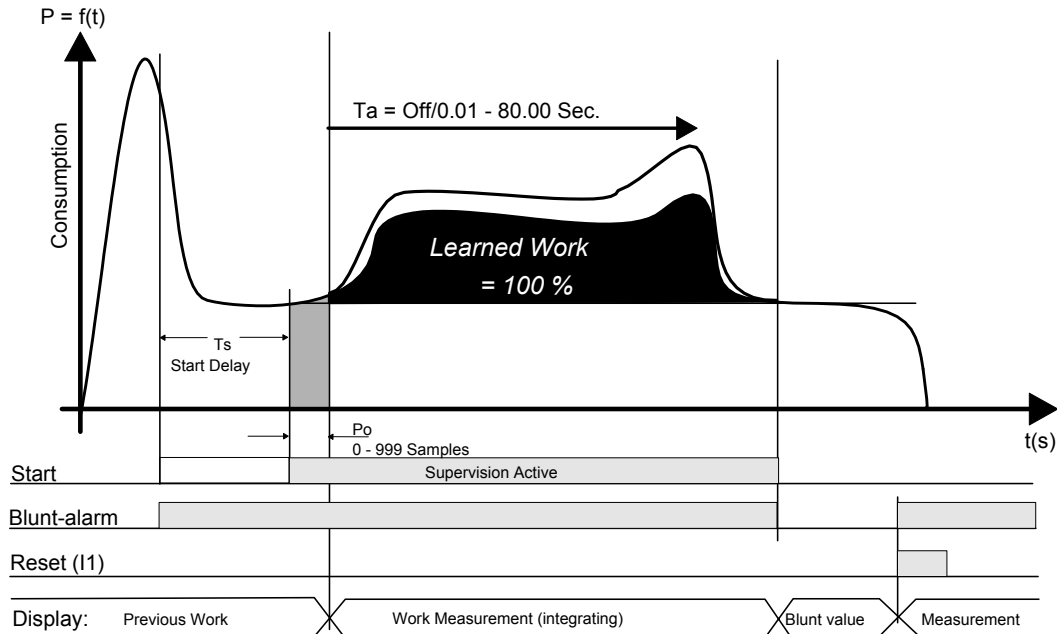

In determining appropriate values for the Missing Limit and Missing Delay, more aggressive monitoring can be achieved with higher Missing Limits and longer Missing Delays (in other words, for a good cycle, the power must stay higher longer). However, setting these parameters too aggressively can result in more frequent nuisance trips. A good compromise and starting point for adjustment seems to be to set the Missing Limit fairly low, around 3 - 5 % (since if the tool is missing, there will be NO rise above idle), and to set a Missing Delay of about 3/4 of the total machining time. Better results seem to be achieved by leaving the Missing Limit low, and tuning out nuisance trips by adjusting the Missing Delay.

3.6 Tool Break Supervision

3.6.1 Break Mode Selection

When a tool breaks while it is machining a part, it is typical to notice a sharp, short duration "spike" of torque in the motor. This torque spike is the extra energy being used by the machine to actually break the tool. The **Techna Check**[®] system can detect this spike, and indicate a broken tool. (It should be noted that not all tools break the same way every time, and that a torque spike may not necessarily be generated in the process of breaking the tool. In this case, a missing tool condition should be noticed on the following cycle.)

There are three **Break Modes**, **Absolute Peak Mode**, **Learn Peak Mode** and **Absolute Peak Curve**, which are described below.

3.6.2 Tool Break -- Absolute Peak Mode

The figure below shows a typical tool break situation, including the setting of the tool **Break Limit**. The Break Limit is a user-defined percentage increase above the Idle Power. If the Break Limit is exceeded for a cumulative time greater than the user-defined **Break Delay**, **Trb**, then a tool break fault will be generated. The red Break LED is illuminated whenever the measured power is above the Break Limit, and flashes whenever a Tool Break alarm is generated. Missing Tool supervision remains active for the duration of **Tw**, if **Tw** is enabled. If **Tw** is turned off, Missing Tool supervision remains active the entire time the start signal is present, following the **Start Delay** and the idle power measurement.

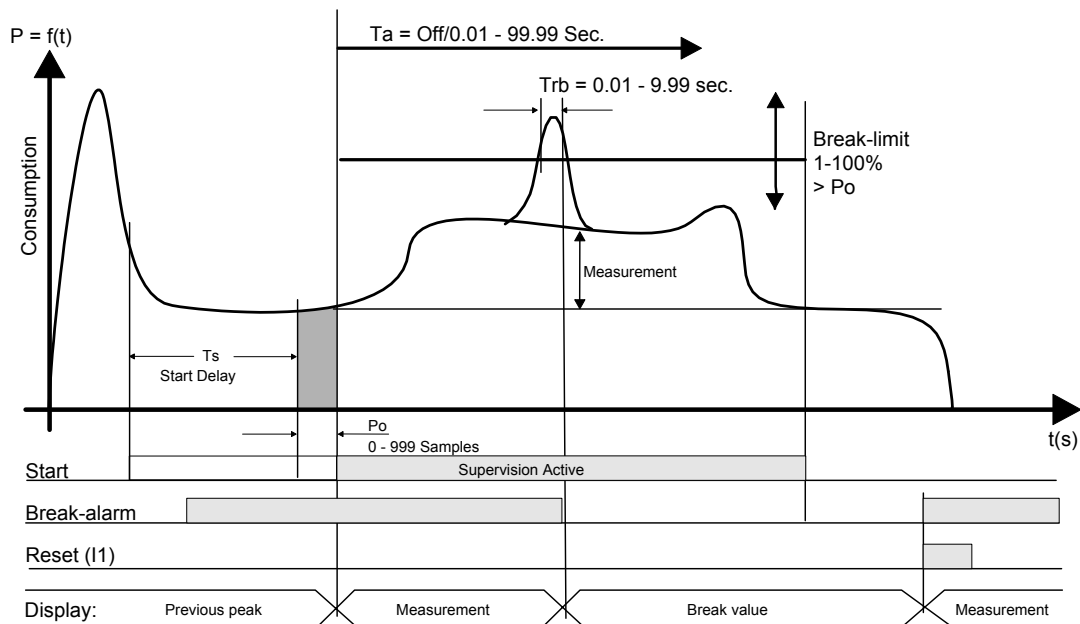

In setting the Break Limit and Break Delay, more aggressive monitoring is achieved by setting a lower limit and shorter delay. However, setting these parameters too aggressively will result in increased nuisance trips. In typical applications, the Break Limit is set fairly high (between 25 and 50%), but with a very short Break Delay (often the minimum 0.01 second). When a tool break occurs, the rise in torque is often quite dramatic, so a high limit and short delay would be best to eliminate nuisance faults.

3.6.3 Tool Break -- Learn Peak Mode

The figure below shows a typical tool break situation, including the setting of the tool Break Limit in Learn Mode. The Break Limit in Learn Mode is a user-defined percentile increase of the power consumption above the Idle Power PLUS the Learned peak power. If the Break Limit is exceeded for a cumulative time greater than the user-defined Break Delay, T_{rb} , then a tool break fault will be generated. The red Break LED is illuminated whenever the measured power is above the Break Limit, and flashes whenever a Tool Break alarm is generated. Missing Tool supervision remains active for the duration of T_w , if T_w is enabled. If T_w is turned off, Missing Tool supervision remains active the entire time the start signal is present, following the **Start Delay** and the idle power measurement.

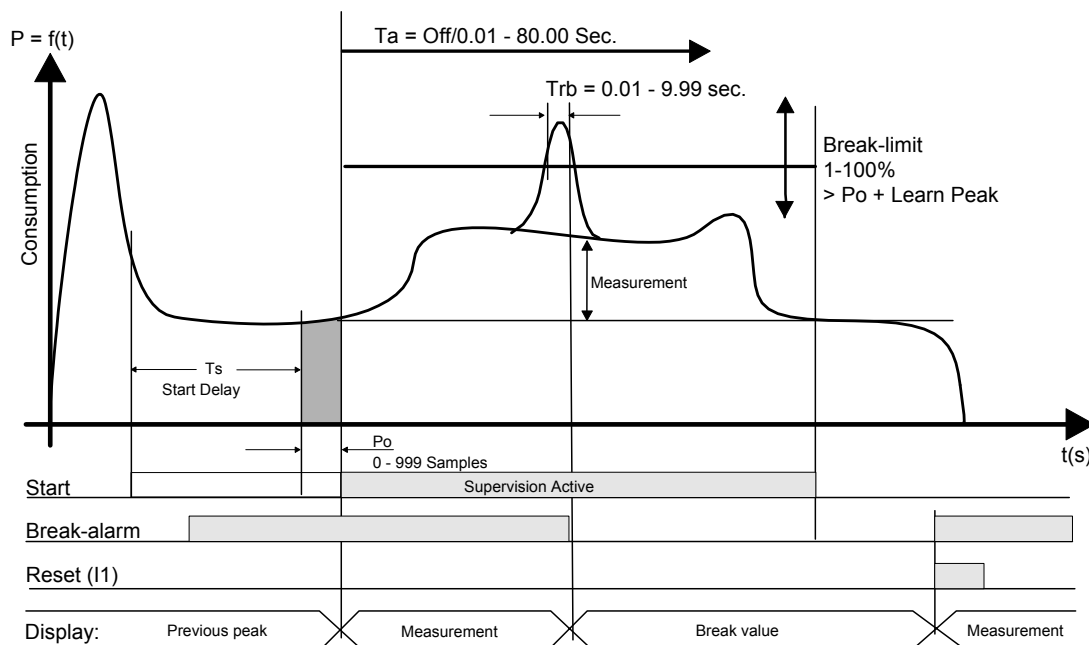

Setting the Break Limit and Break Delay in Learn Mode is much the same as in the Absolute Peak Mode, except that the Break Limit in Learn Mode will “move” with respect to the learned cut. This adaptation allows the unit to adjust to changes in grind from one tool to the next.

3.6.4 Tool Break -- Absolute Peak Curve

The Absolute Peak Curve mode works just like Absolute Peak Mode, but the limit changes in a step fashion as a function of time. This mode may well be used to supervise step tools. If the Break Limit is exceeded for a cumulative time greater than the user-defined **Break Delay, Trb**, then a tool break fault will be generated. Missing Tool supervision remains active for the duration of **Tw**, if **Tw** is enabled. If **Tw** is turned off, Missing Tool supervision remains active the entire time the start signal is present, following the **Start Delay** and the idle power measurement.

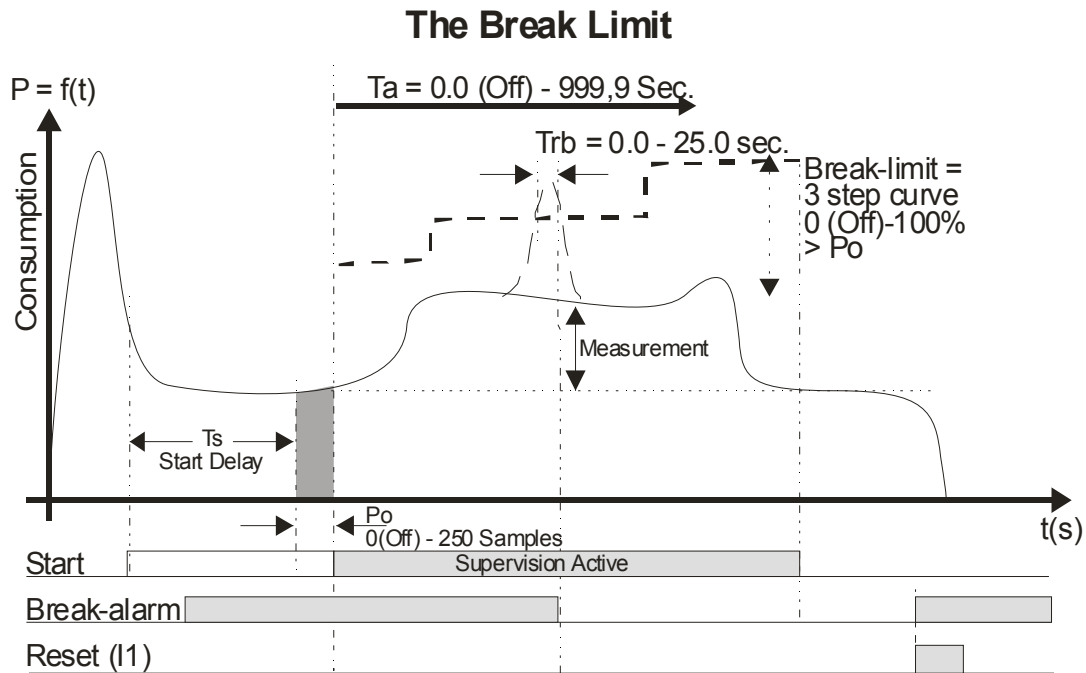

In setting the Break Limit and Break Delay, more aggressive monitoring is achieved by setting a lower limit and shorter delay. However, setting these parameters too aggressively will result in increased nuisance trips. In typical applications, the Break Limit is set fairly high (between 25 and 50%), but with a very short Break Delay (often the minimum 0.01 second). When a tool break occurs, the rise in torque is often quite dramatic, so a high limit and short delay would be best to eliminate nuisance faults.

Note! This mode may well be used to monitor threading operations. The first step is used to monitor the forward threading and the middle step is set to zero, while the direction of the tool changes and the last step is then used to supervise the reverse threading (pulling the threading tool out of the part).

3.7 Blunt Tool Supervision

3.7.1. Blunt Mode Selection

As a tool wears, it is normal for its cutting surfaces to become less efficient, and thus it requires more torque to cut the part. The **Techna Check**[®] system is designed to look for this rise in torque, and to stop the machine when a tool has reached a point where it would be desirable to change it.

There are four **Blunt Modes**. If **Absolute Peak Mode** is selected, the detection of blunt tools is based on the value of the instantaneous torque measurement above idle. In **Absolute Work Mode**, the detection of blunt tools is based on the area under the torque curve for the duration of the cutting cycle, which is proportional to the work or energy used to cut the part. Peak Mode is recommended for most simple machining operations. Work Mode may be used when there are multiple or changing load levels observed during the cycle, such as when a step tool or complicated boring tool is used. Additionally a **Learn Peak Mode** is implemented, which allow the system to automatically adjust to changes in grind from one tool to the next.

Finally a blunt alarm may also be generated by reaching a certain number of manufactured good parts.

In any blunt mode, the use of the **Show Statistics** option from the TOOLMON software package is helpful in setting appropriate values for the **Blunt Limit**. When a computer running TOOLMON is connected to the **Techna Check**[®] system, it is continually keeping track of the peak torque or work used in each cycle. This data may be viewed in the Show Statistics display. This display will give you an idea, over time, of how the tool has worn, and where an appropriate Blunt Limit may be set.

Also in blunt mode, the **Blunt Counter** feature is available. In order to reduce the number of undesired nuisance trips, the Blunt Counter may be set to require a number of consecutive blunt tool faults to be detected before the machine is signaled to stop. For example, a hard part or temporary chip build up may cause a blunt fault to occur in one cycle, but the condition may not be present again in the next cycle. In this case, a Blunt Counter setting of, for example, three would require this condition to occur three cycles in a row before a blunt trip stops the machine. In typical applications, a Blunt Counter setting from 2 to 5 is generally used, depending on material consistency and chip build-up, but higher settings may be used.

3.7.2 Blunt Tool - Peak Mode

The figure below shows a typical blunt tool situation using Peak Mode monitoring, including the setting of the tool Blunt Limit. The Blunt Limit is a user-defined percentage increase above the Idle Power. If the Blunt Limit is exceeded for a cumulative time greater than the user-defined Blunt Delay, T_{rs} , then a tool blunt fault will be generated. The red Blunt LED is illuminated whenever the measured power is above the Blunt Limit, and flashes whenever a Blunt Tool alarm is generated. Blunt Tool supervision remains active for the duration of T_a , if T_a is enabled. If T_a is turned off, Blunt Tool supervision remains active the entire time the start signal is present, following the Start Delay and the idle power measurement.

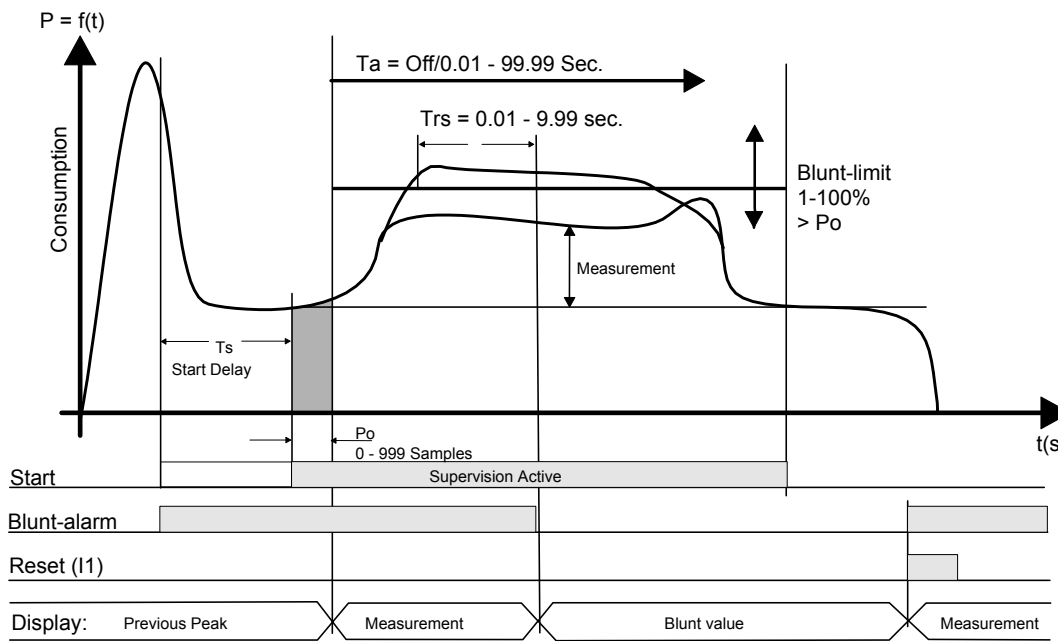

In setting the Blunt Limit and Blunt Delay, more aggressive monitoring is achieved by setting a lower limit and shorter delay. However, setting these parameters too aggressively will result in increased nuisance trips. As a tool wears, the load will gradually increase, and will eventually stay at a higher level for the entire duration of the cut. In typical applications, the Blunt Limit is set fairly low (between 10 and 25%), but with a fairly long Break Delay (often around 75% of the total duration of the cut). Adjustments are then made based on data from the Show Statistics display, usually leaving the Blunt Delay alone, but changing the Blunt Limit.

3.7.3 Blunt Tool - Learn Peak Mode

The figure below shows a typical blunt tool situation using Learn Peak Mode monitoring, including the setting of the tool Blunt Limit. The Blunt Limit is a user-defined percentile increase above the Idle Power PLUS the Learned Peak. If the Blunt Limit is exceeded for a cumulative time greater than the user-defined Blunt Delay, T_{rs} , then a tool blunt fault will be generated. The red Blunt LED is illuminated whenever the measured power is above the Blunt Limit, and flashes whenever a Blunt Tool alarm is generated. Blunt Tool supervision remains active for the duration of T_a , if T_a is enabled. If T_a is turned off, Blunt Tool supervision remains active the entire time the start signal is present, following the Start Delay and the

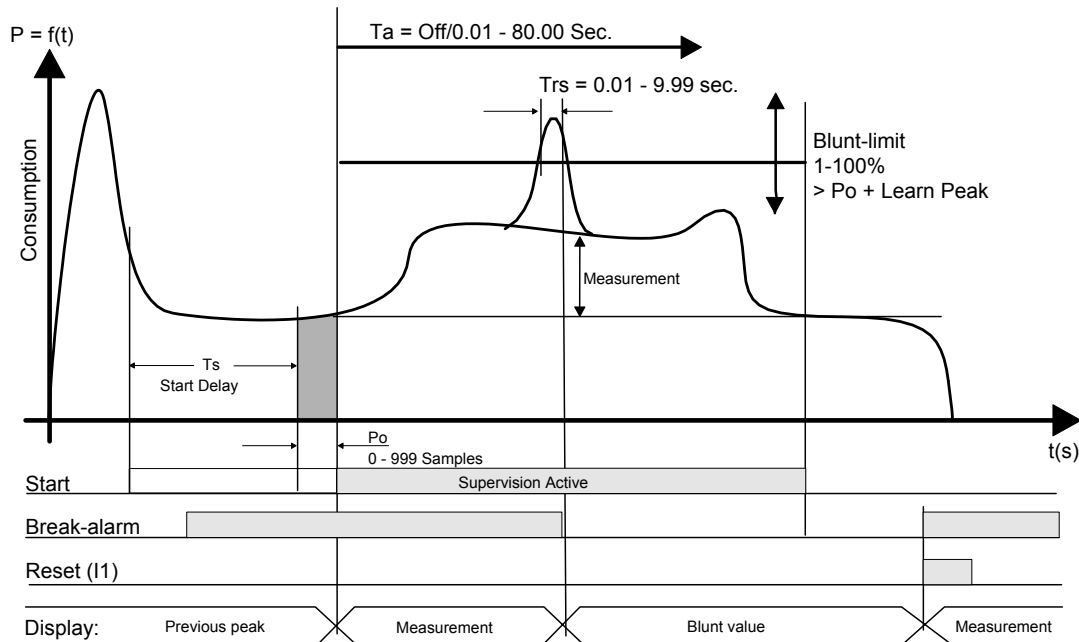

idle power measurement.

Setting the Blunt Limit and Blunt Delay in Learn Peak Mode is much the same as setting them in regular Peak Mode. The addition of the Learn function means that the monitoring limit will automatically adjust for variations in grind from tool to tool.

3.7.4 Blunt Tool - Learn Work Mode

The figure below shows a typical blunt tool situation using Learn Work Mode monitoring, including the setting of the tool Blunt Limit. The work, or energy consumed, during the cutting cycle is proportional to the black area in the figure. The Blunt Limit is a user-defined percentage increase above the Learned Work. A fault is generated if the measured work exceeds the percentage increase over the Learned Work (note that the Blunt Delay becomes inactive in Work Mode). The red Blunt LED flashes whenever a Blunt Tool alarm is generated. Blunt Tool supervision remains active for the duration of T_a , if T_a is enabled. If T_a is turned off, Blunt Tool supervision remains active the entire time the start signal is present, following the **Start Delay** and the idle power measurement. **Because Work Mode monitoring calculates total energy used in the entire cycle, any faults will always be signaled at the end of the cycle.**

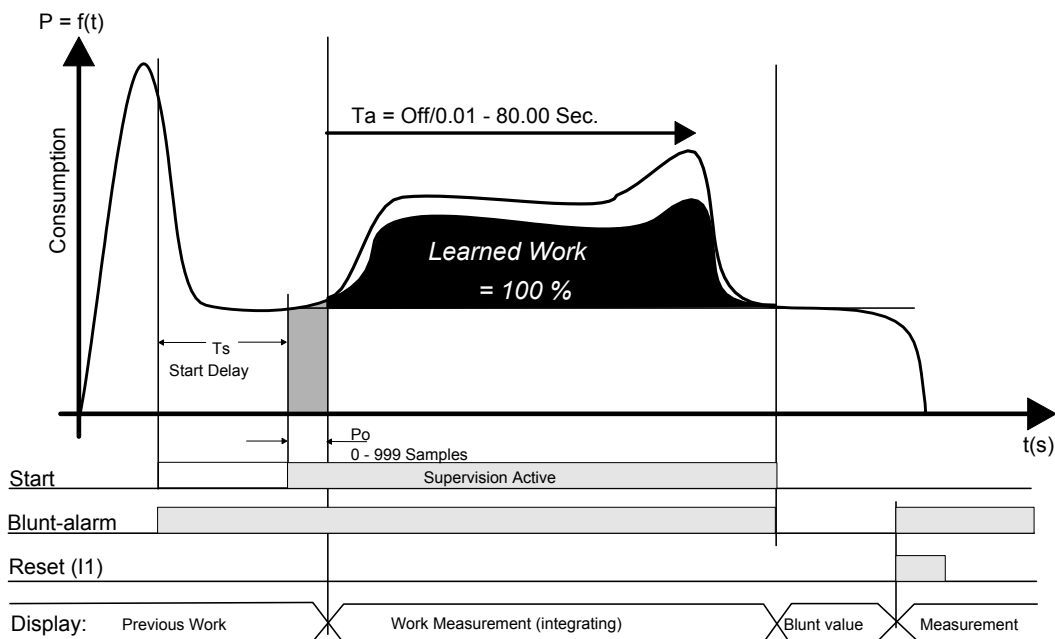

Setting the Blunt Limit in Learn Work Mode is much the same as setting the limit in regular Work Mode. The Learn feature gives the system the ability to adjust monitoring for differences in tool grind from one tool to the next.

3.7.5 Blunt On Good Parts Counting

Besides using a Torque or Work limit to detect a Tool Blunt condition a 'good part count' may be used as well.

The TC101 maintains a counter of good parts manufactured. This counter is only reset in two conditions:

1. A learn cycle is initiated.
2. An alarm caused by part counter overflow was reset.

Please use the TOOLMON application to set the part count limit and to enable the count alarm.

3.8 Idle Power Monitoring

In some applications, it may be necessary to check that the machine idle power is within certain boundaries. For example, a very low idle power may indicate that a belt is broken or that there is no power to the motor. A very high idle power may also indicate belt problems, or problems with lubrication or bearings. In these cases, a high and low limit, PoMax and PoMin (parameters #3 and parameter #4), for the idle power may be set. After the idle power is measured and Po is calculated, the value is compared with PoMax and PoMin. If it is not within the limits, then a Tool Break fault occurs immediately.

Each of the Idle Power Monitoring limits may be disabled by turning them all the way down to zero.

3.9 TC102 - Touch Point Limit

The TC102 implements a special software and hardware version in order to implement the **Touch Point Function**. The analogue input is modified to accept the 0—10 V power output generated by the drive - please consult the drawing on page 25 for wiring. All the Tool Monitor Alarms (Blunt, missing and break) have been combined to be signaled on the same relay. The relay #2 is then used for the Touch Point Function.

Relay #2 output may be used as a touch point indication. If a Touch Point Limit greater than zero has been programmed the relay no. 2 is closed when the power consumption reaches a threshold equal to $P_o + \text{Touch Point Limit}$. The relay #2 contacts are released again, when the start signal is removed.

This function may be used in some systems to tell the tool feed mechanism that a tooling operation has begun and the feed rate needs to be decreased. The tooling cycle may be shortened if a different, faster feed rate can be used until the tool touches the target.

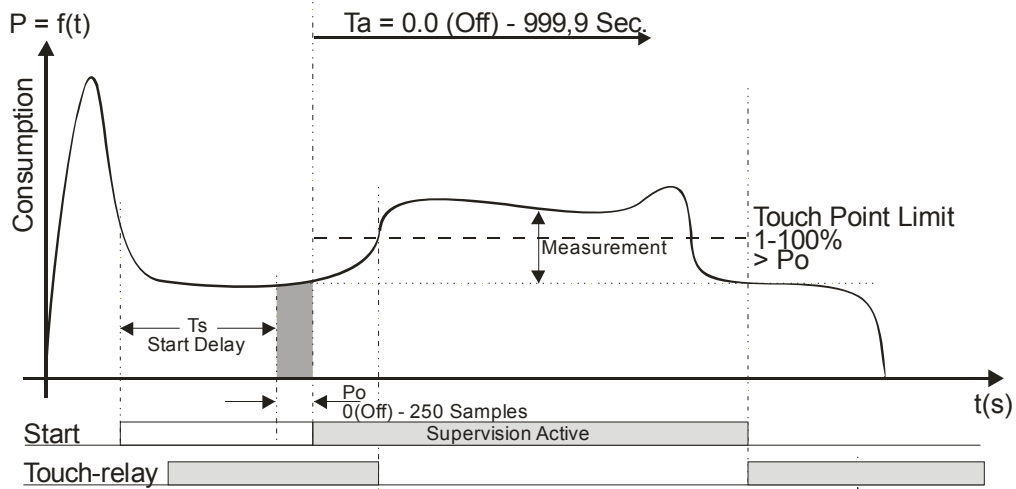

Parameter #9 (Parameter Mode) is the Touch Point Limit.

4. Programming and display

4.1 Display



During normal system operation, the display on the front of the unit will show the instantaneous power being used while the system is receiving a Start Signal from the machine. After the Start Signal ends, indicating that monitoring should stop and the machining is finished, the display will show the maximum power measured during the cycle.

4.2 Locking and Unlocking

The **Techna Check**[®] system is programmed by the use of four keys located on the front panel. Ordinarily, the unit must be "unlocked" before parameters may be altered from the front panel. To unlock the unit, the MODE key is pressed eight times, until the display shows "On". Both arrow keys are pressed and held for approximately 5 seconds, until the display changes to "Off" and the "Locked" LED starts flashing. The system can be locked again by pressing the RESET key.

4.3 Primary Monitoring Limits and Timers

Once the system is unlocked, the MODE key is used to switch the LED display from showing power to showing one of the programmable limits or timers. The limits and timers and their programming ranges are listed in the table below. LED's will illuminate to show which parameter is being viewed and modified. When the green Tr LED is illuminated, along with the condition LED, it indicates that that particular fault delay is being view (i.e., Tr LED and Break LED indicated that the Break Delay is displayed). When a variable has been selected, it may be changed by pressing the arrow keys. Holding an arrow key pressed for about 5 seconds will cause the value to scroll continuously until the key is released. All values are stored in non-volatile memory, and should not need to be restored in the event of a power failure.

 Mode	Function	Variable		+		Display	Defaults
Power[kW]	kW/kWmax Display			Po	Max. Peak	kW[%]	
Break	Tool-break limit	Off/0.1-100.0%	Decrease		Increase	'Off/Break[%]	50.0%
Blunt	Tool-blunt limit	Off/0.1-100.0%	Decrease		Increase	'Off/Blunt[%]	25.0%
Missing	Tool-missing limit	Off/0.1-100.0%	Decrease		Increase	'Off/Missing[%]	'Auto'
Ts[Sec]	Start Timer	0.01-99.99 Sec.	Decrease		Increase	Start Delay [Sec.]	'Off'
Tr[Sec]	Tool-break reaction timer	0.01-99.99 Sec.	Decrease		Increase	Tr Break [Sec.]	0.01 Sec.
Tr[Sec]	Tool-blunt reaction timer	0.01-99.99 Sec.	Decrease		Increase	Tr Blunt [Sec.]	2.0 Sec.
Tr[Sec]	Tool-missing reaction timer	0.0-99.99 Sec.	Decrease		Increase	Tr Missing [Sec.]	0.5 Sec.
Locked	Programming lock/unlock	'Off'/'On'				'Off'/'On'	'On'
Parameter	Parameter programming	0-20	Decrease		Increase	0-20	0

4.4 Parameter Mode

Parameter Mode is used to set parameters and variables that are usually only changed once. Most of these parameters may also be changed through the use of the TOOLMON software package. To access Parameter Mode, the unit must first be unlocked. Then the MODE key is pressed until the red LED next to "Parameter" is lit. The unit will display the Parameter Number. The Parameter Number may be changed by pressing the arrow keys until the desired Parameter Number is displayed. Once the Parameter Number has been selected, pressing the MODE key will display the value currently programmed for that parameter. Pressing the arrow keys will enter different values for the parameter, as listed below. Pressing RESET will save the changed value. The unit returns to the Parameter Mode, and further changes may be made to other parameters. Pressing RESET again will terminate the Parameter Mode, or after about 10 seconds without a key being pressed, the unit will reset itself.

All Parameters and their functions are listed in the table below. Refer to the appropriate sections of this manual for details of their function.

Parameter	Function
0	No function
1	Averaging: This parameter is used to set the number of power measurement samples that are averaged to perform tool monitoring operations.
2	Po Averaging: This parameter sets the number of idle power samples to average to calculate idle power.
3	Analog Zoom P1Max: Establishes the upper limit of the analog zoom. Refer to the section on "Analog Zoom."
4	Analog Zoom P1Min: Establishes the lower limit of the analog zoom. Refer to the section on "Analog Zoom."
5	Start Delay
6	Idle Max. Limit: This parameter sets the minimum value of idle power (Po) for Idle Power Monitoring.
7	Idle Min Limit: This parameter sets the maximum value of idle power (Po) for Idle Power Monitoring
8	Network Address:
9	Touch Point Limit: TC102 only - If this limit is not zero the Touch Point Function is implemented on relay #2

5. Installation Notes

5.1 Mechanical Mounting

The **Techna Check**[®] system mounts simply through the electrical cabinet. To install the unit, a 66 mm by 66 mm (2.6 inches by 2.6 inches) square hole should be cut in the cabinet. The unit also requires at least 90 mm (3.5 inches) of clearance behind. The PWM125 or the PWM350 module mounts inside the electrical cabinet using standard 35mm DIN rail. It is typical to mount this unit directly beneath the motor drive or starter, since the motor cables are routed through the hole(s) in the unit.

5.2 Electrical Connection

5.2.1 Power

Electrical connections to the **Techna Check**[®] system and PWM125 or PWM350 are as shown in following pages. The current measurement input on the unit is rated for motors with full load ratings up to the rating of the PWM module.

5.2.2 Control Inputs

All control inputs to the module are 24 VDC PLC inputs.

5.2.3 Control Outputs

Fault conditions are signaled to the machine by two sets of relay contacts. In typical applications, the Break/Missing relay is wired to cause an immediate retraction of the machine head, and the Blunt relay is wired to allow the machine to complete its current cycle before stopping the machine. Because the outputs are relays, they will wire into almost any machine control system, whether it uses relay logic or a PLC. It should be noted that the output relays will be open when the unit is not powered.

5.3 Wiring of the PWM125 or the PWM350 Module

For proper operation of the system, it is important that the PWM module be set up properly. Incorrect settings of **Current Measurement Range** may severely reduce the functionality of the system.

5.3.1 Current Measurement Range

The current measurement range of the PWM350 is set by hardwiring or PLC control of two digital inputs. The current measurement range of PWM125 is programmed from the front panel. The appropriate measuring range is selected by determining the Full Load Current (FLA) of the motor, which should be marked on the motor housing. Then the percentage of the rating of the PWM350 unit should be calculated. For example, when using a motor with an FLA rating of 10 Amps with a PWM350 rated at 50 A, the percentage of the PWM350 rating would be 20%. In this case, the 20% range on the PWM350 would be used. In cases where the percentage does not exactly correspond to one of the current ranges on the unit, the next larger range should be used.

It should also be noted that it is permissible to use external current transformers (CT's) in cases where the motor current is above the rating of the PWM350. As an example, if it were desired to monitor a motor having an FLA of 100 Amps, a 20:1 current transformer might be employed. Since the CT has a ratio of 20:1, the maximum current on its secondary would be 5 Amps. Applying the example above, the current measurement range would be set to 10%.

5.4 Interfacing TC101 to PWM125

Note! The wire that feeds through the UniGuard device must be the wire which connects to L3.

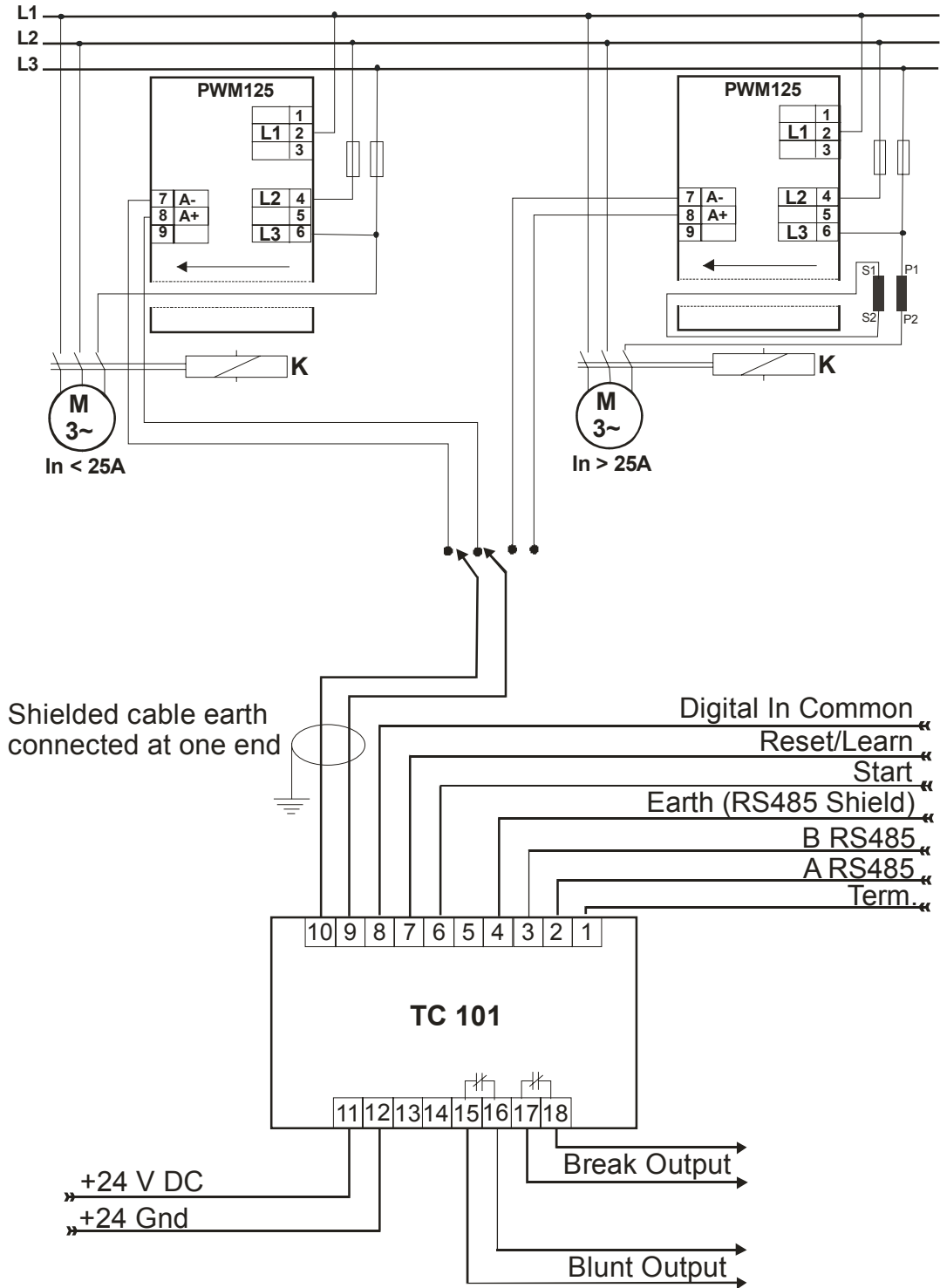

5.5 Interfacing TC101 to PWM350

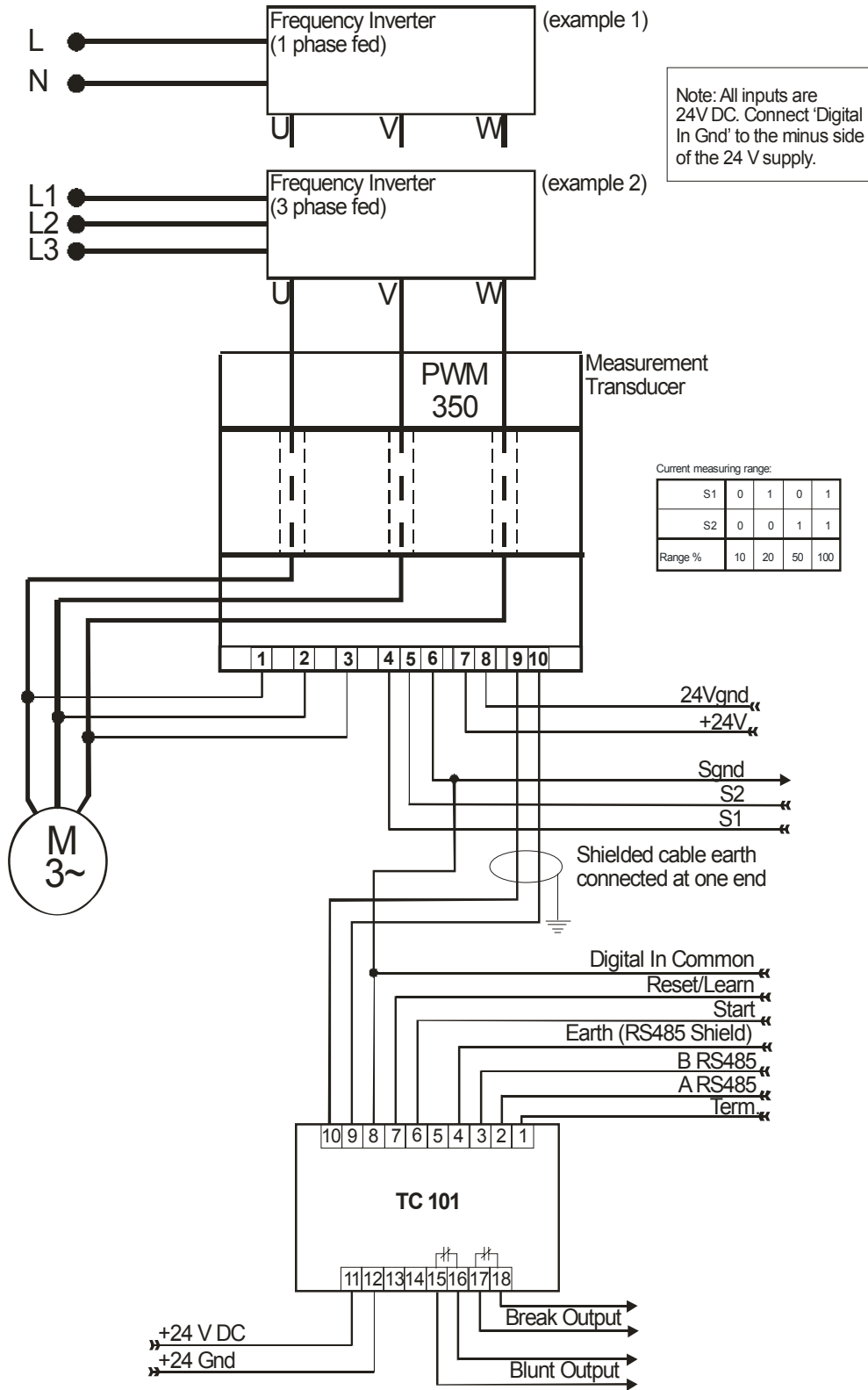

5.6 Interfacing TC102 to Drive with 0 – 10 Volt Output

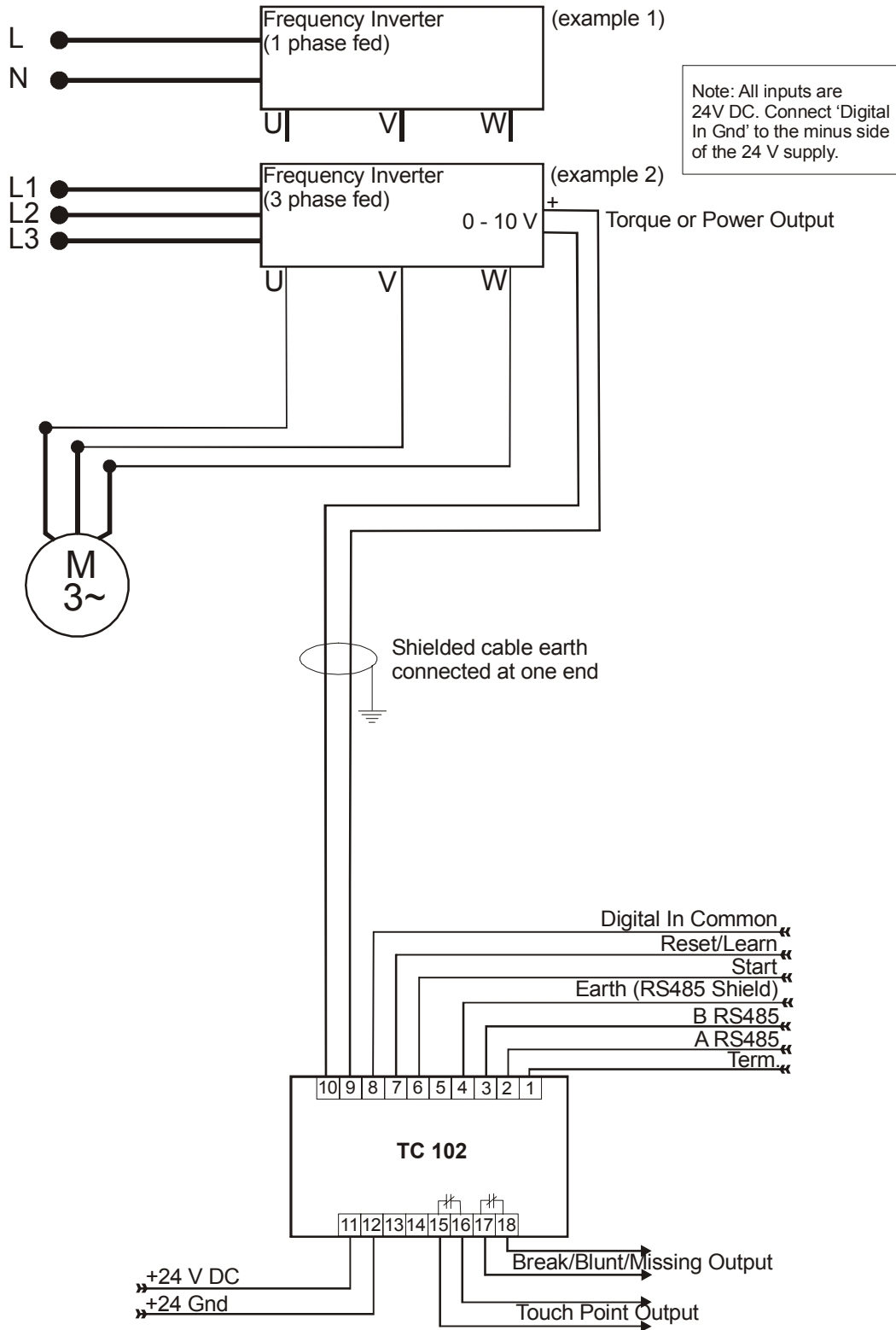

5.7 Networking and Communicating TC101 and TC102

Up to 24 TC101 units may be connected in a network and interfaced to a PC running the TOOLMON application. TOOLMON will be able to modify all parameter and to show the tooling operation graphically. TOOLMON maintain a tool peak and work statistic as well. The network address is programmable from the front of the unit only (parameter #8).

If the RS232 port on the front is used then the unit is disconnected from the network. When Using the RS232 port on the front to program the unit it requires a straight through RS232 cable to communicate. **We recommend not using a USB to RS232 adapter. If your computer does not have a com port on it we suggest using a Siig Single-Serial PC card # JJ-PCM012. WE have found that most of the USB to RS232 adapters will not work with the Techna-Check.**

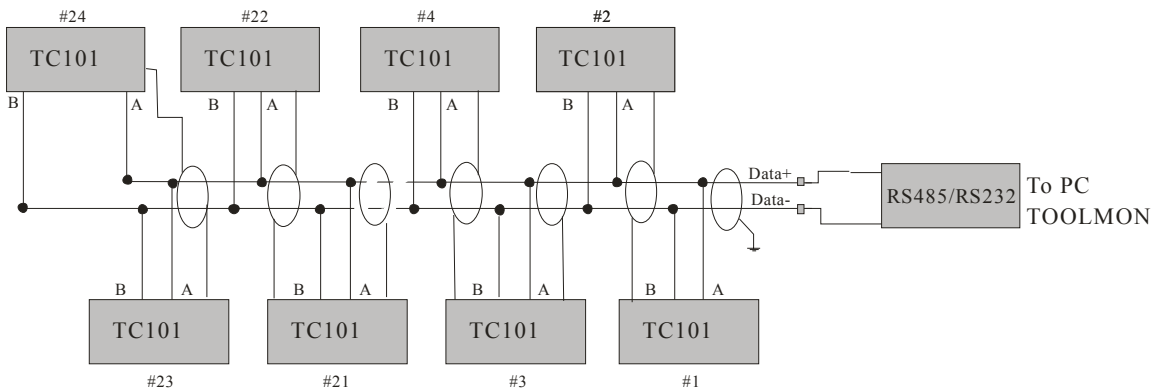

Important note:
 Use twisted and shielded cable.
 Make the stubs as short as possible.

If third party RS485/RS232 converter is used it must be approved by Techna Tool Inc.

6. Ratings and Specifications

6.1 *Techna Check*[®] TC101

6.1.1 Mechanical

Housing:	Noryl DIN 43700, 72mm x 72mm x 85mm
Mounting:	Panel Mount, 66mm x 66mm square cutout from electrical enclosure
Environmental:	IP55 front, IP20 back
Ambient Temp.:	-15 to +50 C
Weight:	Approximately 500g (1 lb.)

6.1.2 Electrical

Supply Voltage:	24V DC
Control Signal Voltage:	24V DC
Power Consumption:	3VA
Relay Outputs:	250 VAC max, 5 A max, Normally Closed, electrically isolated
Analog Input:	0 - 20 mA

6.2 *Techna Check*[®] PWM125

6.2.1 Mechanical

Housing:	Polyamide, D 75 x B 26 x H 111mm (2.95" x 1.02" x 4.37")
Mounting:	35mm DIN rail
Environmental:	IP40 (for use inside electrical enclosures)
Ambient Temp.:	-15 to +50 C
Weight:	Approximately 250g (0.5 lb.)

6.2.2 Electrical

Supply Voltage:	Power supplied from measurement voltage
Measurement Voltage:	see PWM125 side label
Measurement Current:	Max. 25 A internal. Unlimited (external converter)
Control Signal Voltage:	24 VDC
Power Consumption:	1VA
Analog Output:	0 - 20 mA, 0 - 400 ohm, electrically isolated

6.3 *Techna Check*[®] PWM350

6.3.1 Mechanical

Housing:	Polycarbonate, D 118 x B 45 x H 137.5 mm
Mounting:	35mm DIN rail
Environmental:	IP40 (for use inside electrical enclosures)
Ambient Temp.:	-15 to +50 C
Weight:	Approximately 500g (1 lb.)

6.3.2 Electrical

Supply Voltage:	24V DC
Measurement Voltage:	0 - 500 V PWM, three phase, 5 Hz - 5 kHz
Measurement Current:	Max. 50 A
Control Signal Voltage:	24 VDC
Power Consumption:	3VA
Analog Output:	0 - 20 mA, 0 - 400 ohm, electrically isolated

TECHNA-CHECK® PWM3100A Load Transducer

Load Transducer for 1- or 3-phase AC & DC Loads

An ultra-fast measurement transducer specifically developed for Machine Tool Monitoring applications.

PWM3100A measures motor power [kW] or motor current [A].

◆ Analog Output

(0-20 mA) reflecting power or current

◆ 8 Programmable Measurement Ranges

1, 2.5, 5, 10, 15, 25, 50 or 100 Amp.

Digital Design

4 quadrant digital multiplication.

Measures power or current before or after variable frequency inverter.

Ultra Compact DIN rail mount

Less than 2" of rail space.

External Hall-Sensor(s) for Current Measurement

1 or 3 external 100 Amp. custom designed current sensors (Hall-Effect Sensors).

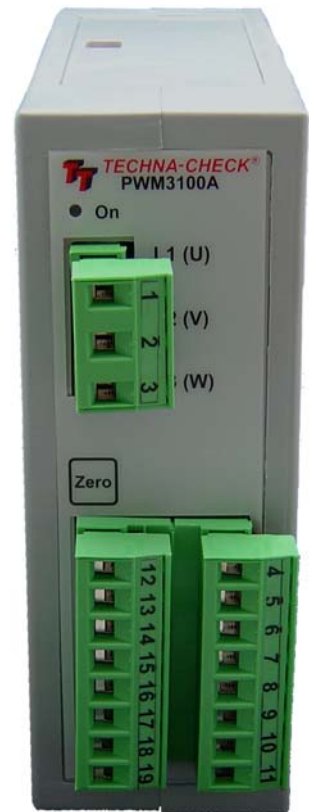

Technical Specification

Mechanical

Housing: Polycarbonate.
 Mounting: 35 mm DIN-rail.
 Protection Class: IP40.
 Temp. Range: -15 to + 50 C.
 Weight: App. 250g.
 Dimensions: D 118 x B 45 x H 137,5 mm.
 Connections: Max 2.5 mm² (AVG 24).

Electrical

Voltage Input: 3 x 0-500 VAC/VDC max.
 Current Input: 3 x 100 Amp. 0 Hz - 35kHz
 Power Range: 0 - 86.5 kW AC. 0 - 50 kW DC.
 Supply: 18-36 V DC max. 2.0 Watt.
 Analogue output: 0 - 20mA, 200 ohm isolated. TC compatible.
 Digital Inputs: 10-30 VDC.
 CE marked to: TBD

Range Select:

The measurement-range is selected from 3 digitally isolated inputs. The inputs may be hardwired or controlled from a PLC.

S3, S2, S1	Range %
0 0 0	1
0 0 24V	2.5
0 24V 0	5
0 24V 24V	10
24V 0 0	15
24V 0 24V	25
24V 24V 0	50
24V 24V 24V	100

0 is zero volt or open circuit (no connection).

Features

The PWM3100A is designed primarily for measuring AC or DC power or current delivered to motors by variable frequency inverters. AC power is measured from the formula:

$$P = \sqrt{3} \times U \times I \times \text{Cos}\phi$$

DC power is measured from the formula:

$$P = U \times I$$

The PWM3100A Power or Current Transducer is specifically developed to function as a load transducer for the **TECHNA-CHECK®** Range of Machine Tool Monitors.

Three opto-coupler isolated inputs allow the selection of 8 measurement ranges: 1 Amp., 2.5 Amp., 5 Amp., 10 Amp., 15 Amp., 25 Amp., 50 Amp. and 100 Amp.

The transducer outputs a current of 0–20mA (200 ohm) compatible to Techna Check TC3200 and Techna Check TC101.

The three motor wires **must** pass through the external hall sensors in the **same direction** to the motor either from Top-Bottom or from Bottom-Up.

TECHNA-CHECK® is a registered trade mark by Techna-Tool Inc., Hartland, Wisconsin USA.

Using the PWM3100A

The operating mode is selected from a dip-switch located at the top of the unit. A small screw driver must be used to access the individual dip switches.

Offset Zeroing:

Offset zeroing is a function that calibrates the Hall Sensors to the unit. Offset zeroing **must be done once** after the Hall Sensors are connected and the spindle (motor) is **NOT** running. The offset-button must be activated for 5 seconds and the green on-led flashes for 5 seconds during the offset adjustment. Calibration values are maintained after power off (saved in EEPROM).

Dip. Switch No. 1 - 2 = Off, Off (Default Operating Mode)

This is the default AC-measurement mode. The PWM3100A measures the current frequency and uses this as a time-base for the measurement. The measurement speed and reaction speed of the unit increases as the spindle speed increases. This mode cannot be used in DC-measurement mode.

Dip. Switch No. 1 - 2 = On, Off

Fixed measuring interval 10 ms (millisecond). May be used in both AC- and DC-mode

Dip. Switch No. 1 - 2 = Off, On

Fixed measuring interval 25 ms (millisecond). May be used in both AC- and DC-mode

Dip. Switch No. 1 - 2 = On, On

Fixed measuring interval 100 ms (millisecond). May be used in both AC- and DC-mode

Dip. Switch No 3: Off = 3-Phase Measurement (Default) On = 1-Phase Measurement

1-Phase measurement is usually used with DC-measurement. Only phase L1(U) must be connected.

Dip. Switch No. 4: Off: Power Measurement (Default), On: Current Measurement

When power is measured after a variable frequency inverter a certain amount of noise is introduced. The noise comes from the high frequency voltage switching (PWM Voltage). In some applications the noise can be eliminated by measuring current only. Measuring current after a frequency converter often has similar sensitivity as power-measurement, but the noise is significantly reduced. The current measurement may be used for monitoring smaller dimension tools. When current is measured the voltage connection terminals 1, 2 and 3 are not used and may be left open.

3-Phase AC-Connection with Frequency Inverter.

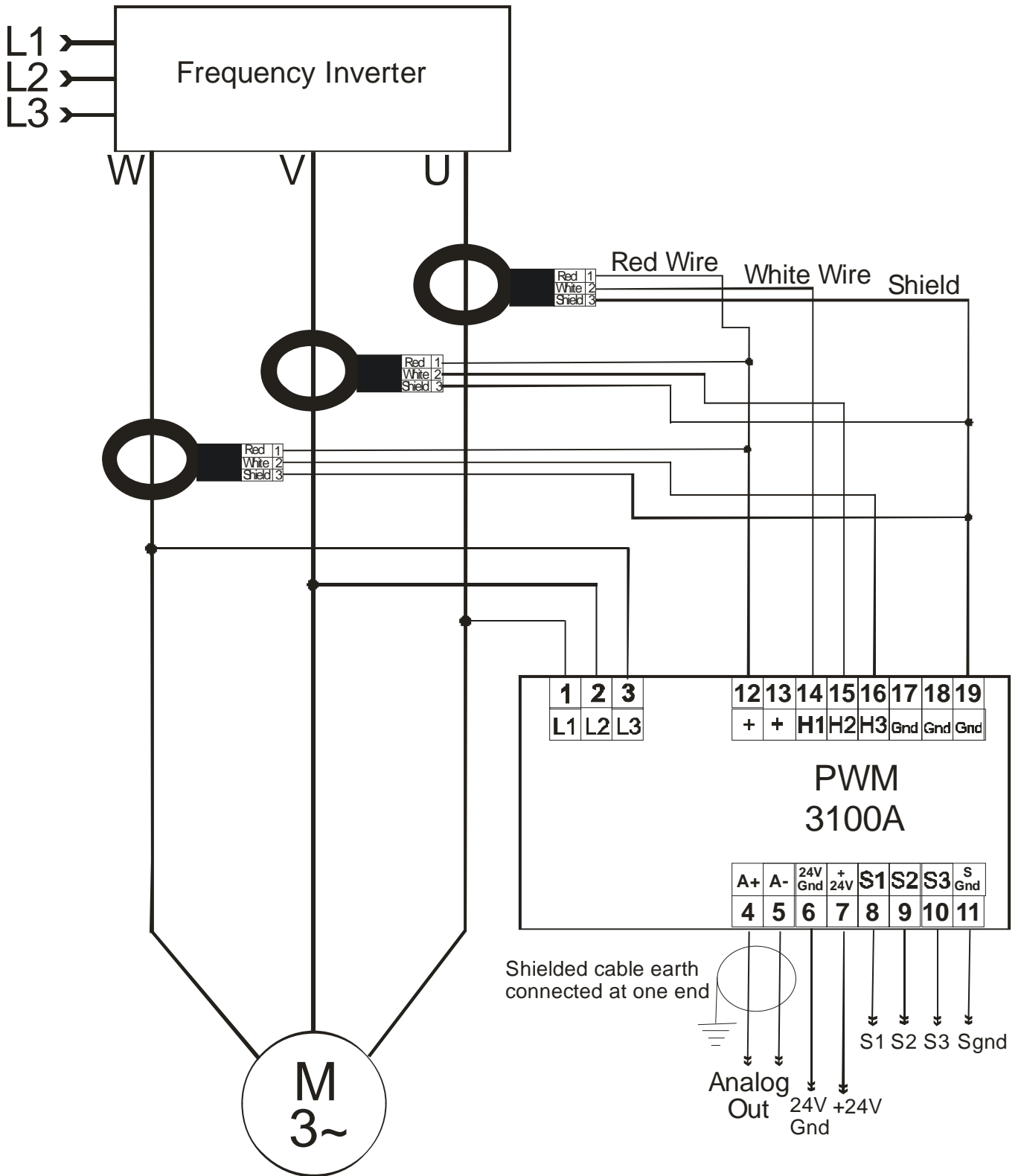

Power Transducer for Symmetrical Loads

A fast measurement transducer specifically developed for Machine Tool Monitoring applications.

PWM125 measures motor power, kW, RMS voltage, RMS current and Power Factor:

- ◆ **Analog Output** (0-20 mA) reflecting power
- ◆ **Programmable Averaging**
- ◆ **Programmable Zoom function**

True Digital Design

*no pots, no dials, no screw-drivers.
144 samples per cycle at 50 Hz.
120 samples per cycle at 60 Hz.
4 quadrant digital multiplication.*

Ultra Compact DIN rail mount

only 1" of rail space.

Current wire feeds through hole in unit

An "Intelligent CT".

Monitor any size motor

*(external CT >25Amp.)
peaks up to 75 Amp measured.*

High precision resolution measurement

works when amp-meters don't!

Measures and displays

*kW, kW[%], RMS Voltage, RMS Current and PF
(Power Factor).*

Peak/Min capture for all variables

Reset by key

Power displayed in true kW

Voltage, Current and Power Factor displayed also

Typical Installation In <= 25 Amp.:

Note! The wire that feeds through the UniGuard device **must** be the wire which connects to L3.

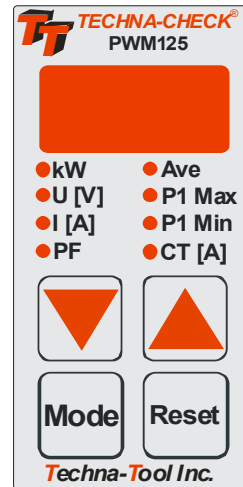
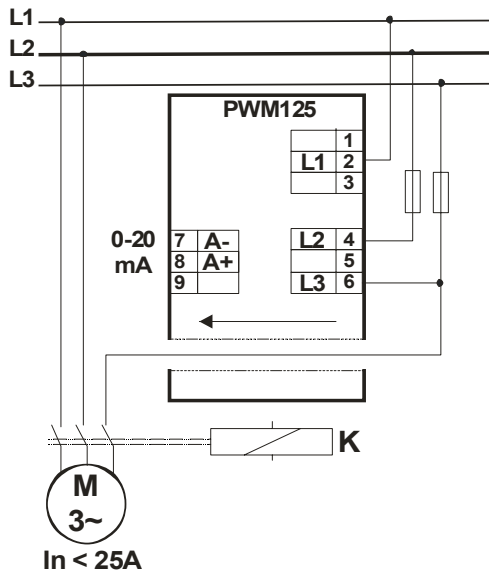

The PWM125 measures true power for symmetrical 3-phase loads from the formula:

$$P = \sqrt{3} \times U \times I \times \text{Cos}\phi$$

The PWM125 Power Transducer is specifically developed to function as a load transducer for the **TECHNA CHECK®** Range of Machine Tool Monitors.

The Tool Monitoring application require very fast measurement in order to be able to detect the breakage of a tool. Averaging is programmable from 0.01-0.1 seconds but normally kept fixed at 0.01 seconds (fastest measurement).

TECHNA CHECK® is a registered trade mark by Techna-Tool Inc., Hartland Wisconsin USA.

Functional Ranges:

Mode	Function	Range
kW	kW Display	measured
U [V]	Voltage Display	measured
I [A]	Current Display	measured
PF	Power Factor Display	measured
Ave	Averaging	0.01—0.1 Sec.
P1Max	P1Max. kW Limit	(P1Min + Range(10%)) - Range[100%]
P1Min	P1Min. kW Limit	0.0 - (P1Max—Range(10%))
CT [A]	Current Range	See table on page 2

When a display mode other than kW is selected the display returns to kW-mode, after no key has been activated for app. 8 seconds.

Technical Specifications:

Electrical

- Voltage Range(s)** - See unit side label for actual range
3 x 220, x 380, x 440, x 460, x 575V
- Current Range** - Internal max. 25 A. External N/1 or N/5 converter
- Cos φ Range** - -1 to +1
- Frequency Range** - 50/60 Hz
- Consumption** - Supply voltage = measurement voltage, 1 VA
- Analogue Output** - 0-20 mA, 0-400 Ohm

Mechanical

- Housing** - Polyamide 6.6—FR. Light Gray RAL 7035
- Mounting** - Snap-on for 35mm DIN rail mounting
- Protection Class** - IP40 DIN VDE 0470, UL94 V-0 (house)
- IP20 (connector)
- Terminals** - Green RAL 6018, 6.5 mm wire stripping length
- 7.5 AWG (2.5 mm) wires max.
- Internal CT Wire Hole** - 21 AWG (7 mm) wire max.
- Op. Temp. Range** - +5 to +122°F (-15 to +50°C)
- Weight** - 1/2 lb (0.25 kg)
- Dimensions** - D 2.95" x B 1.02" x H 4.37"
(D 75 x B 26 x H 111 mm)
- CE mark to** - EN50081-1, EN50082-2, EN61010-1

Typical Installation In > 25 Amp.:

Note! The wire that feeds through the UniGuard device must be the wire which connects to L3.

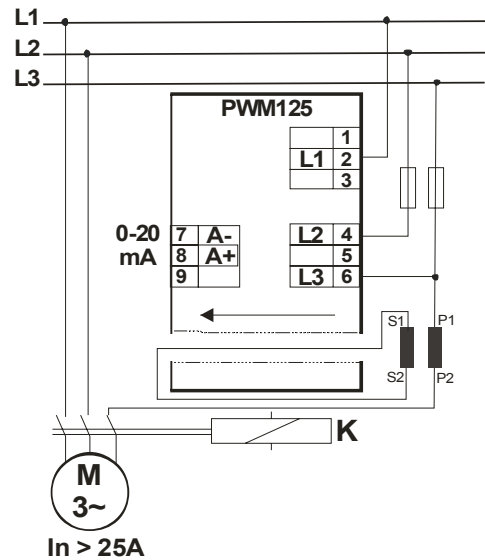

Generally

The power measurement principle is based on digital sampling, 4 quadrant multiplication and integration (summing) of the power in every half period, 10 ms at 50 Hz or 8.33 ms at 60 Hz. The sampling frequency at 7.2 kHz is well higher than many professional power measurement devices. This guaranties true power measurement also for not sine-shaped loads such as the loads generated by variable frequency inverters and soft starters. The PWM125 must always be mounted before variable frequency drives and soft starters (input side).

Programming

The PWM125 is programmed by the use of only three keys located on the front panel. The "Mode" key is used to select display values or one of 4 programmable parameters. When a parameter is chosen the value may be altered by the use of the arrow keys.

Measurement Ranges

The PWM125 has a built-in converter that works up to 25 Amp. One of 25 internal current ranges may be selected or one of 20 external converters. Current up to 75 Amp. is measured in order to ensure correct measurement of non sine shaped loads. The table on the right side of this page show the power range in kW for all possible CT [A] ranges. The kW range is displayed when both arrow keys are activated and the display shows kW or kW[%]. The power range is calculated from the formula:

$$P_{max} = U_{nom} \times CT [A] \times \sqrt{3}$$

Advanced Options:

The advanced options are accessed by holding down the mode and the arrow-up key simultaneously for app. 5 seconds. The display returns to normal mode by pressing the reset key or by no key activation in app. 20 seconds.

Keyboard lock feature

The display will be flashing between showing "Loc" and "On/Off". Lock mode may be changed by the arrow keys. If the keyboard is locked it will be possible to view but not alter variables.

Power measurement option

The display will be flashing between "P" and "Abs/neg". Absolute mode indicates the unit measures the numeric power value ie. negative power is converted to positive. In this mode the direction of the wire through the unit (CT) has no impact, thus a wiring mistake is eliminated. If however "neg" is selected then all negative measured power is set to zero. Power becomes negative, when a motor suddenly behaves as a generator. This is possible

for instance when hoists or cranes lowers a large load. Normally it makes no sense to monitor the generator situation and a negative measurement is set to zero in this mode. In tool monitor applications this feature may be used to ignore spindle reversals. A new Ts will be activated when the motor start to run normally again. The direction of the wire through the CT hole must match the arrow on the side label in this mode of operation.

CT [A]	kW (460V)
Int. 1	0.797
Int. 2	1.59
Int. 3	2.39
Int. 4	3.19
Int. 5	3.98
Int. 6	4.78
Int. 7	5.58
Int. 8	6.37
Int. 9	7.17
Int. 10	7.97
Int. 11	8.76
Int. 12	9.56
Int. 13	10.4
Int. 14	11.2
Int. 15	12.0
Int. 16	12.7
Int. 17	13.5
Int. 18	14.3
Int. 19	15.1
Int. 20	15.9
Int. 21	16.7
Int. 22	17.5
Int. 23	18.3
Int. 24	19.1
Int. 25	19.9
Ext. 50/1	39.8
Ext. 75/1	59.8
Ext. 100/1	79.7
Ext. 125/1	99.6
Ext. 150/1	120
Ext. 200/1	159
Ext. 250/1	199
Ext. 300/1	239
Ext. 400/1	319
Ext. 500/1	398
Ext. 50/5	39.8
Ext. 75/5	59.8
Ext. 100/5	79.7
Ext. 125/5	99.6
Ext. 150/5	120
Ext. 200/5	159
Ext. 250/5	199
Ext. 300/5	239
Ext. 400.5	319
Ext. 500/5	398

PWM125 Connection to TC101

Note! The wire that feeds through the UniGuard device must be the wire which connects to L3.

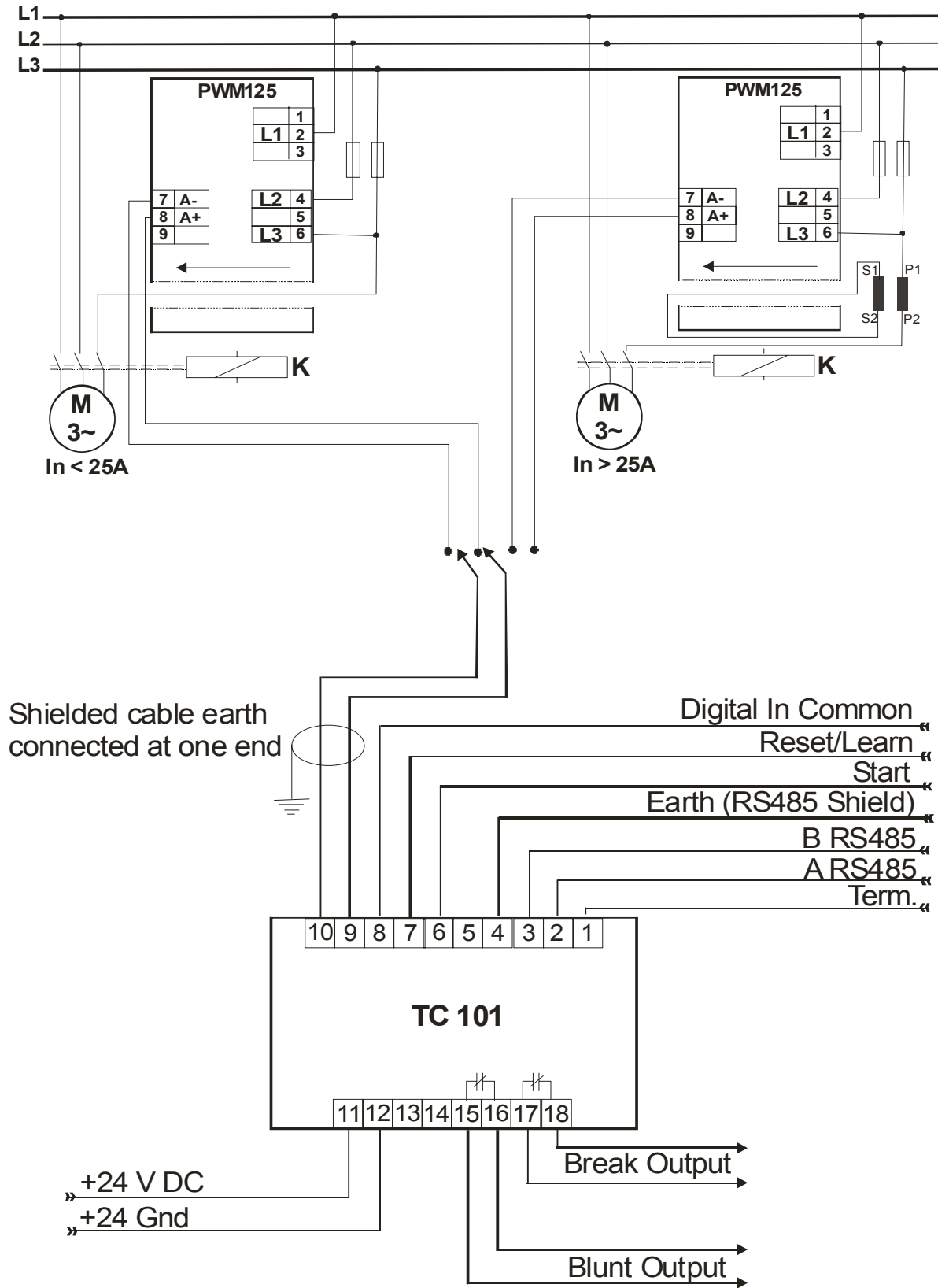

PWM125 Connection to TC3200

Note! The wire that feeds through the UniGuard device *must* be the wire which connects to L3.

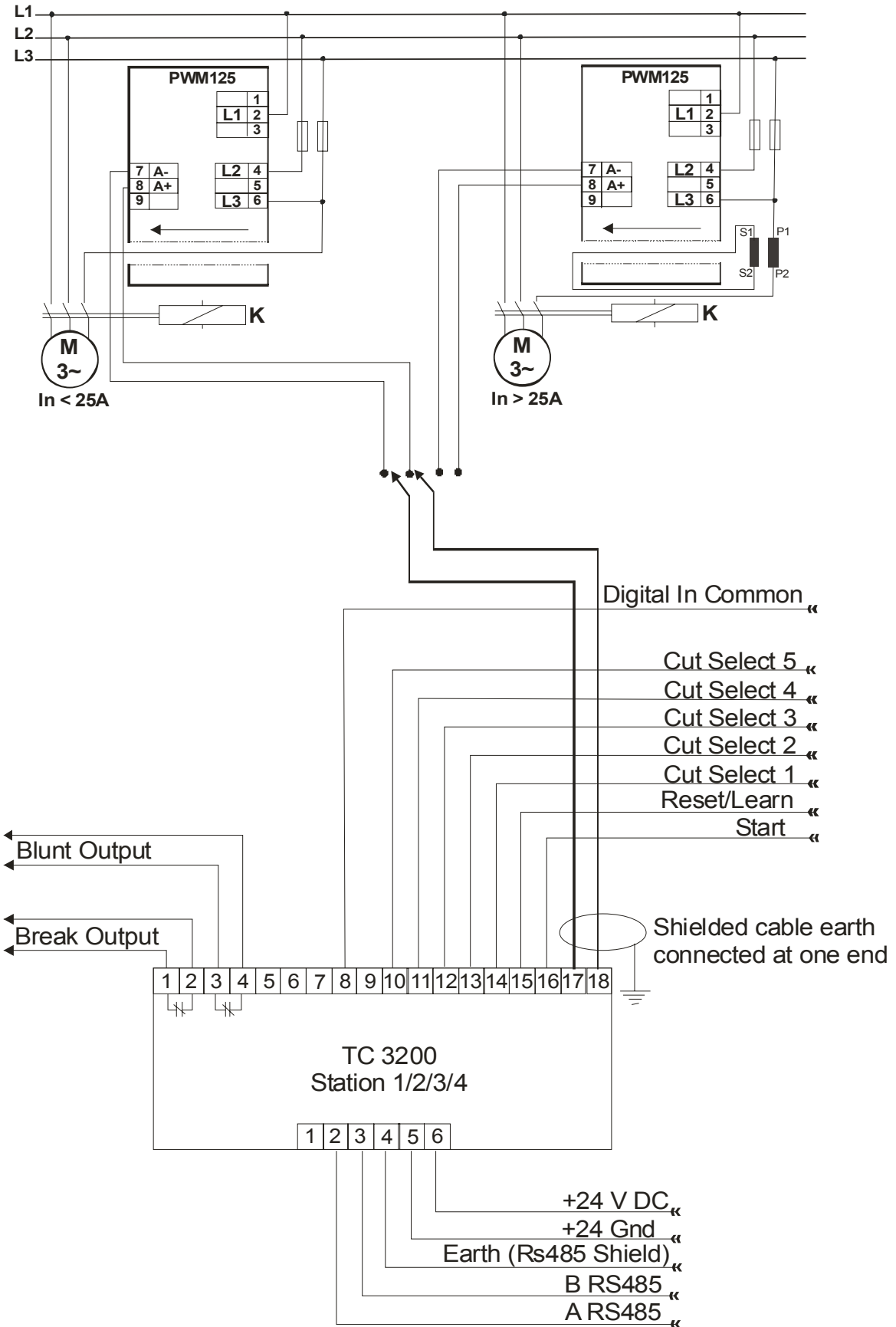

Note! Earth connected to housing inside TC3200

Vibration Sensor Interface

A measurement transducer providing Vibration Monitoring for the **TECHNA CHECK®** units: TC3200, TC6400 and TC101.

VM100 measures vibration (acceleration)

- ◆ Analog Output (0-20 mA) reflecting vibration
- ◆ 4 Programmable Measurement Ranges
- ◆ 4 Programmable RMS averaging periods
- ◆ Programmable low-pass filter

Technical Specification

Mechanical

Housing: Polycarbonate.
 Mounting: 35 mm DIN-rail.
 Protection Class: IP40.
 Temp. Range: -15 to + 50 C.
 Weight: App. 300g (1 lb).
 Dimensions: D 118 x B 45 x H 137,5 mm.
 Connections: Max 2.5 mm² (AVG 24).

Electrical

Sensor Input: Proprietary. Sensor supplied with unit.
 Vibration Range: +- 0.5G, 0 - 1000 Hz
 Supply: 18-24 V DC max. 2.5 Watt.
 Analogue output: 0 - 20mA, 0 - 400 ohm isolated.
 Digital Inputs: 10-30 VDC.

Measurement Ranges

The measurement range is selected by hardwiring or PLC control of the two inputs S1 and S2. Small tools usually generate small vibrations and one of the low ranges must be used.

Range:	100%	50%	20%	5%
MaxG	+- 0.5G	+- 0.25G	+- 0.1G	+- 0.01G
S1	Open	Open	+	+
S2	Open	+	Open	+

RMS Averaging Period

The RMS averaging period is selected by hardwiring or PLC control of the two inputs S3 and S4. 25 ms (millisecond) averaging will do well for most cases. If the vibrations are of very low frequency 100 ms may be selected and for higher frequencies a value less than 25 ms may be selected.

Time	100ms	25ms	10ms	1ms
S3	+	Open	Open	+
S4	Open	Open	+	+

Low Pass Filter

A low pass filter may be activated from the dip. switches no. 1 and 2 on the front. When the filter is activated higher frequency vibrations are suppressed. The dip. switch no. 3 and 4 are reserved for future use.

Sw1	Sw2	Function
Off	Off	No low-pass filter
On	Off	100 Hz low-pass filter
Off	On	500 Hz low-pass filter
On	On	1000 Hz low-pass filter



The VM100 interfaces a proprietary acceleration sensor to the existing **TECHNA CHECK®** range of Machine Tool Monitors.

The purpose of the vibration monitoring is to catch damage of a tool such as a milling cutter which has damaged one of its inserts. When one insert is broken the next insert is forced to cut twice the amount of material, which will generate machine vibrations that are picked up by the VM100.

The VM100 has 4 measurement ranges which can be selected from two opto-coupler isolated inputs. A green LED on the front will show which range is selected. The green LED will be flashing at a low frequency to signal the internal microprocessor is alive and operating.

The VM100 has 4 RMS Averaging periods, which can be selected from two opto-coupler isolated inputs.

The transducer outputs a current of 0–20mA proportional to vibration, which is galvanically isolated from the measurement system.

TECHNA CHECK® is a registered trade mark of Techna-Tool Inc., Hartland Wisconsin USA.

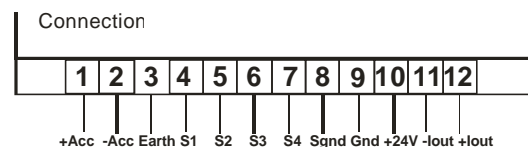

Digital inputs S1, S2, S3 & S4

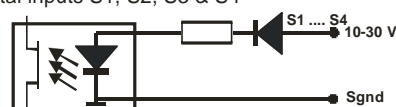

VM100 Connection to TC3200

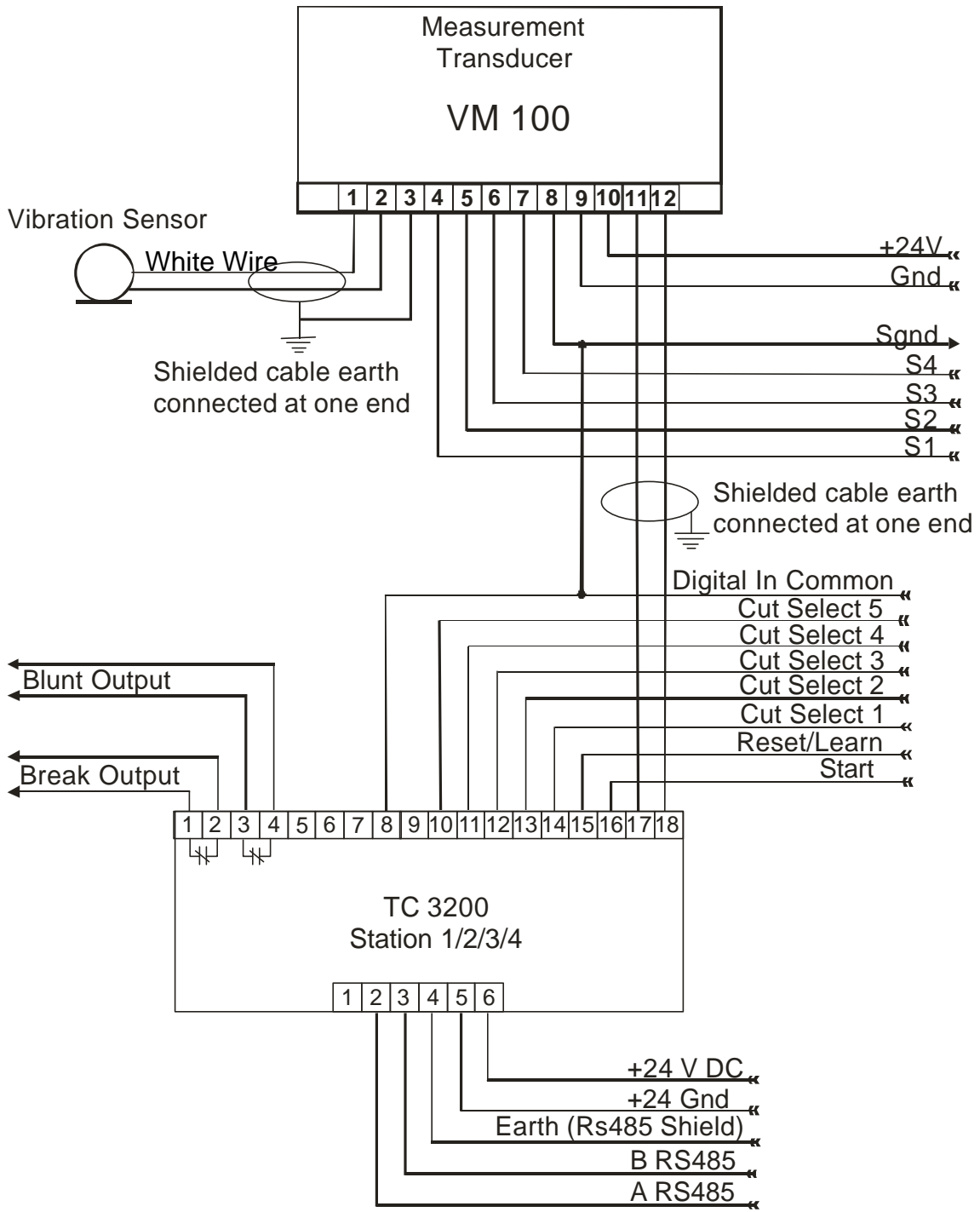

Note! Earth is not used (connected) inside VM100
 Earth is connected to housing inside TC3200

VM100 Connection to TC101

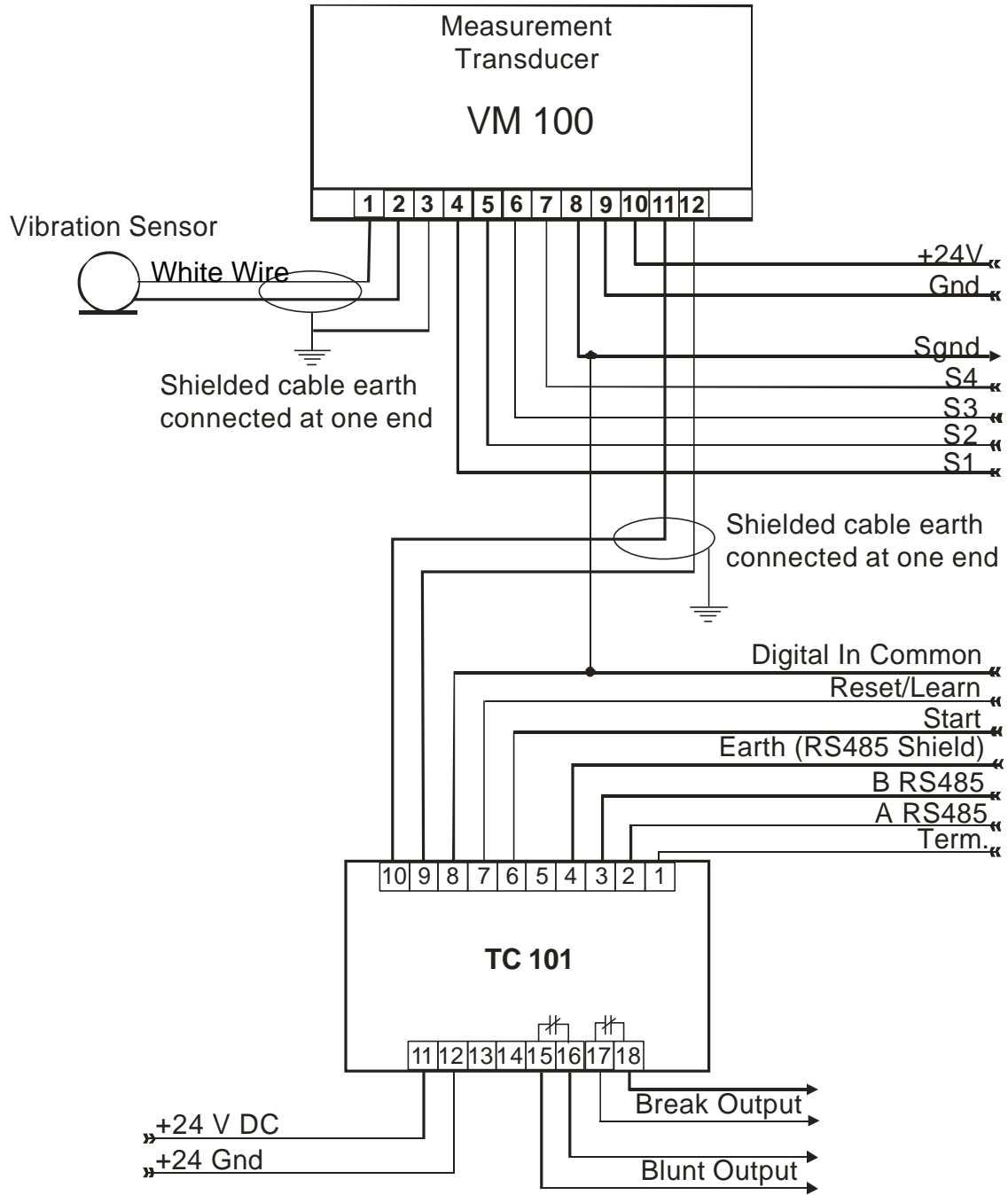

Power Transducer for 3-phase Inductive Loads

A fast measurement transducer specifically developed for Machine Tool Monitoring applications.

PWM350 measures motor power, kW.

- ◆ **Analog Output** (0-20 mA) reflecting power
- ◆ **4 Programmable Measurement Ranges**

Analogue Design

*4 quadrant analogue multiplication.
Measures power after variable frequency inverter.*

Ultra Compact DIN rail mount

Less than 2" of rail space.

Current wires feeds through 3 holes in unit

3 internal 50 Amp. current sensors.

Monitor any size motor

(external CT >50Amp.)

Technical Specification

Mechanical

Housing: Polycarbonate.
Mounting: 35 mm DIN-rail.
Protection Class: IP40.
Temp. Range: -15 to + 50 C.
Weight: App. 500g (1 lb).
Dimensions: D 118 x B 45 x H 137,5 mm.
Connections: Max 2,5 mm² (AVG 24).

Electrical

Voltage Input: 3 x 0-500 V PWM (0-600V max).
Current Input: 3 x 50 Amp. 5Hz - 5kHz or
3 x 25 Amp. 5Hz - 5kHz or
3 x 12,5 Amp. 5Hz - 5kHz
see side label for actual range
Power Range: 0 - 43.3 kW.
Supply: 18-36 V DC max. 2.5 Watt.
Analogue output: 0 - 20mA, 0 - 400 ohm isolated.
Digital Inputs: 10-30 VDC.
CE marked to: EN50081-1, EN50082-2,
EN61010-1.

Measurement Ranges

The measurement range is selected by hardwiring or PLC control of the two inputs S1 and S2.

Range	3 x 50 Amp.	3 x 25 Amp.	3 x 12,5 Amp
100%	43.3 kW	21,7 kW	10,8 kW
50%	21.7 kW	10,8 kW	5,42 kW
20%	8.66 kW	4,33 kW	2,17 kW
5%	2.17 kW	1,08 kW	0,54 kW

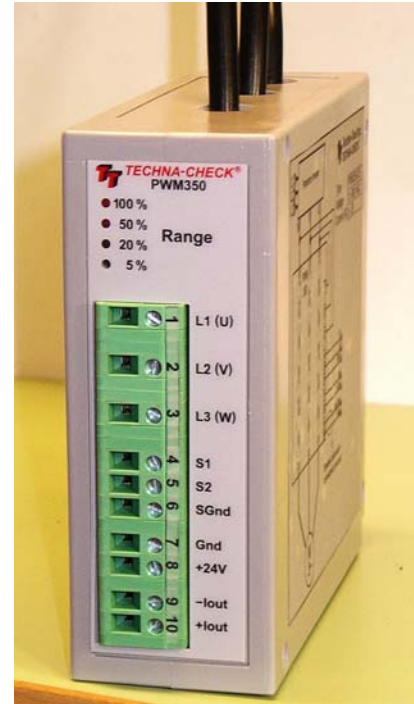

The PWM350 is designed primarily for measuring the power delivered to motors by variable frequency inverters. Power is measured from the formula:

$$P = \sqrt{3} \times U \times I \times \cos\phi$$

The PWM350 Power Transducer is specifically developed to function as a load transducer for the **TECHNA CHECK®** Range of Machine Tool Monitors.

The PWM350 is available as a 3 x 50 Amp, 3 x 25 Amp or a 3 x 12,5 Amp transducer..

Two opto-coupler isolated inputs allow the selection of 4 measurement ranges 100%, 50%, 20% and 5%. The transducer outputs a current of 0-20mA proportional to power, which is galvanically isolated from the measurement system.

The three motor wires **must** pass through the wholes in the transducer in the **same direction** to the motor either from Top-Bottom or from Bottom-Up.

Note: The PWM350 is designed for use with inductive loads only (motors).

TECHNA CHECK® is a registered trade mark by Techna-Tool Inc., Hartland Wisconsin USA.

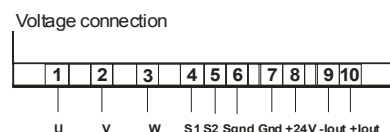

Digital inputs S1 & S2

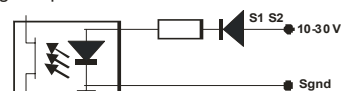

PWM350 Connection to TC3200

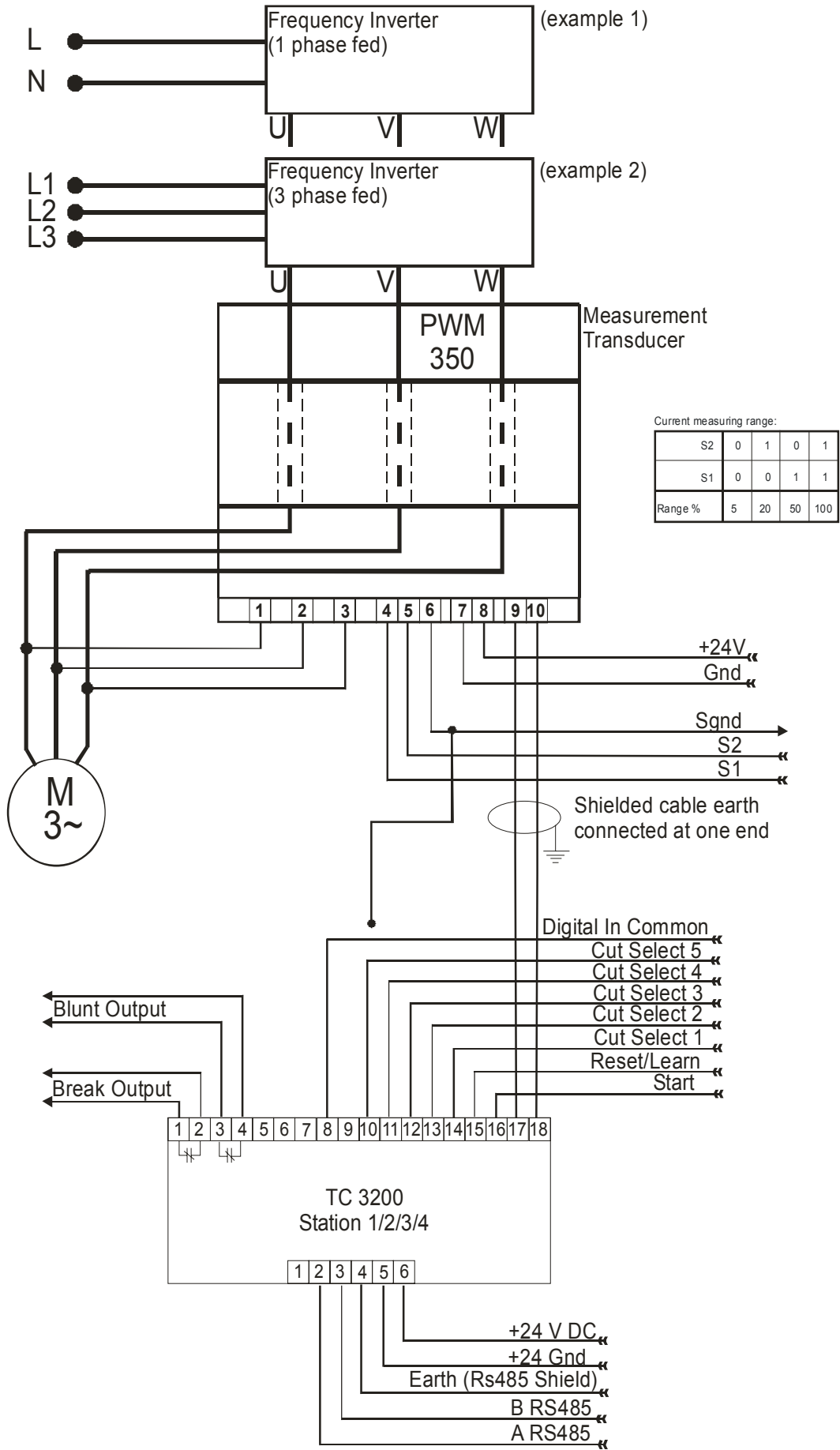

Note! Earth connected to housing inside TC3200

PWM350 Connection to TC101

