



BK MIKRO 8 PB

Control System for Tool Breakage and Object Monitoring
with PROFIBUS Interface

Operating Instructions
Issue 2.00 dated 3.2.2005



553 Industrial Dr. Hartland, WI 53029 Phone 262-367-8665 Fax 262-367-0208
web-site www.techna-tool.com email techtool@techna-tool.com

General Notice

Safety guidelines

These operating instructions contain notices which you should observe to ensure your own personal safety, as well as to protect the product and connected equipment. These notices are highlighted in the manual by a warning triangle and are marked as follows according to the level of danger:



Immediate danger

to life and limb of personnel and others.
Non-compliance may cause death or serious (crippling) injury.



Hazardous situation

to life and limb of personnel and others.
Non-compliance may cause death or serious injury.



Potentially hazardous situation

Non-compliance may cause slight injury;
possible damage to property.



Notes on correct handling

Non-compliance may cause damage to the product and/or damage to parts/items in the vicinity.



Environmental protection

Non-compliance may have an impact on the environment.

Intended use



BK MIKRO is a control system suitable for tool as well as for object and free space monitoring applications. It may only be used for the applications described in the technical documents, and only in connection with devices or components from other manufacturers which have been approved or recommended by us.

This product can only function correctly and safely if it is transported, stored, set up, and installed correctly, and operated and maintained as recommended.

Qualification of personnel

Only qualified personnel may carry out the following activities on the control system: installation, commissioning, operation, maintenance.

Qualified persons in accordance with the safety guidelines are defined as persons who are authorized to commission, to ground, and to tag circuits, equipment, and systems in accordance with established safety practices and standards.

Disclaimer of liability

We have checked the contents of this document for agreement with the hardware and software described. Since deviations cannot be precluded entirely, we cannot guarantee full agreement. However, the data in this manual are reviewed regularly and any necessary corrections included in subsequent editions. Suggestions for improvement are welcomed.

EEC directive EMC 89/336/EEC

The following applies to BK MIKRO control system:



Products which carry the CE symbol meet the requirements of the EEC directive 89/336/EEC on electromagnetic compatibility.

The EEC declarations of conformity and the related documentation will be maintained at the following address for inspection by the responsible officials in accordance with article 10(1) of the above stated EEC directive:

MSC Tuttlingen GmbH
Rudolf-Diesel-Straße 17
78532 Tuttlingen

Areas of use

Control systems of the BK MIKRO series meet the applicable, harmonized, European standards for the respective area of applications.

Fitting conditions

The fitting conditions and safety notes in the operating instructions must be adhered to when commissioning and operating the devices.

Copyright

These operating instructions are intended for the operator and the operator's personnel only. This document and its contents may not be disclosed to third parties, either in full or in part, by reproduction, transmission or any other means without express written authority.

Non-compliance may lead to prosecution under criminal law.

Contents

1	Characteristics	3
2	System Components	4
2.1	Control unit	4
2.1.1	Technical data.....	5
2.1.2	Connection terminals	7
2.2	Scanner	8
2.2.1	Characteristic properties	8
2.2.2	Technical data.....	9
3	PROFIBUS-DP	10
3.1	Operating mode.....	10
3.2	Construction	11
3.3	Electric design (Physical Layer).....	12
3.3.1	Interface	12
3.3.2	LED's to indicate status information.....	13
3.3.3	Address setting.....	13
3.4	Configuration.....	14
3.5	Process data: Output words 2 and 3	15
	Control word AW2	15
	Angle set value AW3	15
3.6	Status words: Input words 2 and 3	16
	Status word EW2	16
	Angle EW3	16
3.7	Parameter.....	17
	Parameter identification AW1	17
	Parameter identification EW1	17
3.7.1	Parameter list	18
3.7.2	Declarations concerning parameters	19
4	Installation Notes	21
4.1	Mounting bracket.....	21
4.2	Interference prevention	21
4.3	Tolerance Calculation:.....	22

Table of Figures/Tables

Fig. 2-1:	Control unit – front view with connections	4
Fig. 2-2:	Control unit – dimensions	5
Fig. 2-3:	Scanner	9
Fig. 3-1:	Construction of a typical BK MIKRO 8 PB system.....	11
Fig. 3-1:	PROFIBUS-DP interfae	12
Fig. 3-2:	Light-emitting diodes.....	13
Fig. 3-3:	DIP switch S1	13
Tab. 3-4:	Parameter list	18
Fig. 4-1:	Mounting bracket.....	21
Appendix A Model 8 Manufacturing and Techna-Tool Part Numbers.....		23

Purpose



These operating instructions are part of the documentation of the BK MIKRO 8 PB. They provide service personnel and system advisors with the information required to install, commission, operate and maintain the BK MIKRO 8 PB.

© Copyright MSC Tuttlingen GmbH, 78532 Tuttlingen, 2002

These operating instructions are available as article no. **68 36 239**.

Subject to change without notice.

1 Characteristics

BK MIKRO 8 PB is a control system suitable for tool as well as for object and free space monitoring applications.

The complete BK MIKRO 8 PB system comprises

- a control unit
- a sensor (scanner),
- a connection cable.

BK MIKRO 8 PB is based on existing design concepts for tool, object and free space monitoring and can be used universally for different types of monitoring by the integration of multifarious functions:

- Object monitoring, Tool monitoring, free space monitoring with PROFIBUS connection.
Tool monitoring with specification (angle/tolerance) of PROFIBUS master (SPS/PLC)
- Tool monitoring without PROFIBUS connection.
Monitoring of the scanning position whose precise location has been previously entered by "Teach-in", e.g. to carry out a tool check before each working cycle.
Through five selection inputs up to 32 tools can be learned and monitored.

Principle of operation

The wand of the scanner scans tools, objects or critical process spaces free of potential, in line with machine cycles.

A control unit equipped with a micro-computer triggers the movement of the wand upon an external signal or about a PROFIBUS message and passes the scanning result and PROFIBUS messages on to the machine control via relay contacts.

The galvanically isolated inputs and outputs guarantee a high degree of operational safety and protection against interferences.

Further features

- Scanning in clockwise (CW) or counter-clockwise (CCW) direction
- Two steps for scanning intensity
- Output relay contacts selectable as normally open or normally closed
- Ranges of tolerance for "O.K." message adjustable
- Indication of the scanning result by two LED's "O.K." and "K.O." on the control unit
- Detection of cable breaks

2 System Components

2.1 Control unit

The BK MIKRO 8 PB control unit consists of:

Power board / Bus board	Control board
Connection: PROFIBUS-DP 9 pin Sub-D socket to connect PROFIBUS Connection: Power supply 24 VDC 4 pin, keyed terminal block Connection: Grounding PE 4 pin, keyed terminal block Connection: Relay outputs "O.K." and "K.O." 4 pin, keyed terminal block	Connection: Scanner 8 pin plug to connect scanner Connection: Inputs optional (Start, Teach, Selection) 2 x 4 pin, keyed terminal block Light-emitting diodes Four LED's to indicate status information

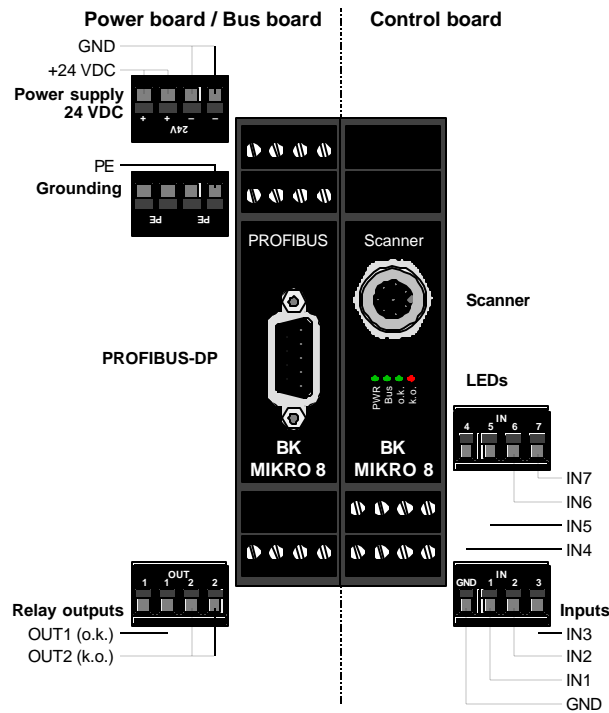

Fig. 2-1: Control unit – front view with connections



Note:

These plugs may only be inserted or removed when the power supply has been disconnected.

2.1.1 Technical data

Housing	Insulating material housing, protection class II, built-in unit
Protection type	IP 20
Dimensions (W x H x D)	45 mm x 99 mm x 114.5 mm
Case mountings	Sectional rail, 35 mm, to DIN EN 50022
Power supply voltage	24 VDC \pm 20% PELV ¹⁾ $I_{max} = 0.4$ A
Power consumption	10 VA max.
Control voltage	24 VDC \pm 20% PELV ¹⁾
Inputs - Input current - Pulse duration	Galvanically isolated 5 mA approx. 40 ms min.
Switched outputs	2 x 30 VDC, 2 A max.
Operational life of relay	5×10^7 switching cycles
Connections	Plug-in screw terminals for connecting - power supply - grounding - relay outputs - control inputs, selection input Scanner, small circular socket, 8 pin PROFIBUS, Sub-D socket, 9 pin
Climatological conditions	Classification 3K3 under EN 50178
Ambient temperature	0 °C to +50 °C
Storage temperature	-25 °C to +80 °C

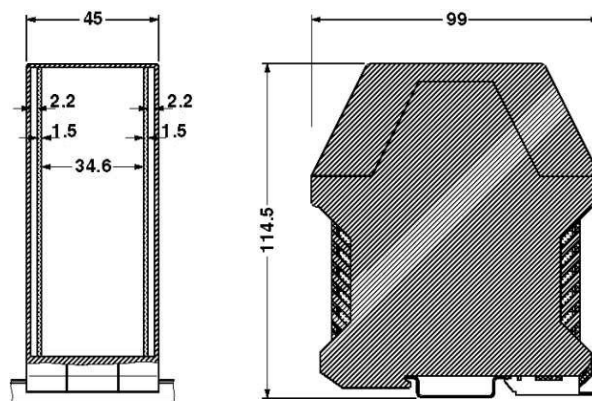

General tolerances
ISO 2768 – mK

Fig. 2-2: Control unit – dimensions



Note:

The control unit of BK MIKRO 8 PB is a **built-in unit** !

¹⁾ PELV = Protected Extra Low Voltage

The voltage applied must meet the requirements for an extra low function potential

with safe disconnection (PELV).

Connection terminals

24V – power supply 24 VDC

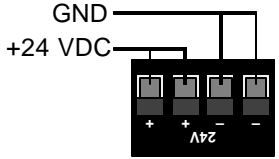
	+	Input of 24 VDC supply voltage (2 terminals)
	-	Reference potential of 24 VDC supply voltage (2 terminals)

PE – potential earth

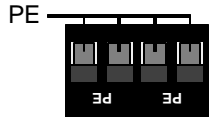
	PE	Connection to earth potential (4 terminals)
---	-----------	--

OUT – relay outputs

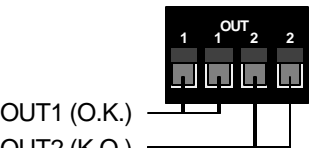
	1	O.K. relay Indication of a no fault message (O.K.) (2 terminals)
	2	K.O. relay Indication of a fault message (K.O.) (2 terminals)

The terminals have been designed as dry relay contacts. By internal parameters, they may be configured as either normally closed or normally open.

The contacts have been designed for 24 VDC and, by additional internal circuits, protected against inductive switch-off peaks of up to 19 W (2 ms).



Note:

Relay as normally closed contact:	active	=	open
	inactive	=	closed
Relay as normally open contact:	active	=	closed
	inactive	=	open

When there is **no power** to the unit, the **contacts always** will be **open**.

Even when using relay as normally closed, they are open (like the active status) when the power supply is not connected.

IN – control inputs and selection input

	GND	Reference potential for control inputs and selection input
	1	"Teach" - control input An input level of +24 VDC relative to "GND" terminal will trigger a learn cycle (the "Teach-in").
	2	"Start" - control input An input level of +24 VDC relative to "GND" terminal will trigger a "Start" cycle (the real scanning process).
	3	"Tool position" - selection input 0 = inactive = active
	4	Selection input 1
	5	Selection input 2
	6	Selection input 3
7	Selection input 4	

Through the 5 selection inputs 32 different tool positions can be reached.
The selection of the tool positions is effected in an binary way, that means that through activating and deactivating the different positions can be reached.

e.g. Tool position	Selection inputs				
	S4	S3	S2	S1	S0
0	L	L	L	L	L
10	L	H	L	H	L
23	H	L	H	H	H
31	H	H	H	H	H

L $\hat{=}$ Low (free or 0 V)

H $\hat{=}$ High (24 V)

2.2 Scanner

2.2.1 Characteristic properties

The scanner housing is cylindrical and smooth, thus permitting easy installation (e.g. by using the mounting bracket). The scanner is designed for easy access for servicing and changing the wand. Aligning the scanner is easy and requires no additional instruments or aids.

The BK8SC scanner offers two special features:

- Scanning wands up to a length of 380 mm
allow if required greater distance between tool and/or object and scanner.
- Scanning plate at the scanning wand
makes it possible to use the scanner directly at the tool magazine to control the tool's tip.
The BK8SC scanner has a mechanical backstop that limits the rotary movement of the wand.

Using scanner BK8SC with a different control unit than BK MIKRO 8 PB may damage the scanner and control unit.



Note:

The wand is a wearing part.

Due to the injury hazard, users should exercise particular caution within any BK MIKRO rotating area.

2.2.2 Technical data

Housing	Anodized aluminum
Protection type	IP 67
Wand length	380 mm, with scanning plate 80 mm x 15 mm, 284 mm, with scanning plate 65 mm x 15 mm, exchangeable wand
Scanning angle	300° max. (with backstop)
Control unit connection	Small circular connector, M12x1, 8 pin
Ambient temperature	0 °C to +80 °C
Storage temperature	-25 °C to +85 °C
Scanning cycles	> 5 million at minimum scanning intensity

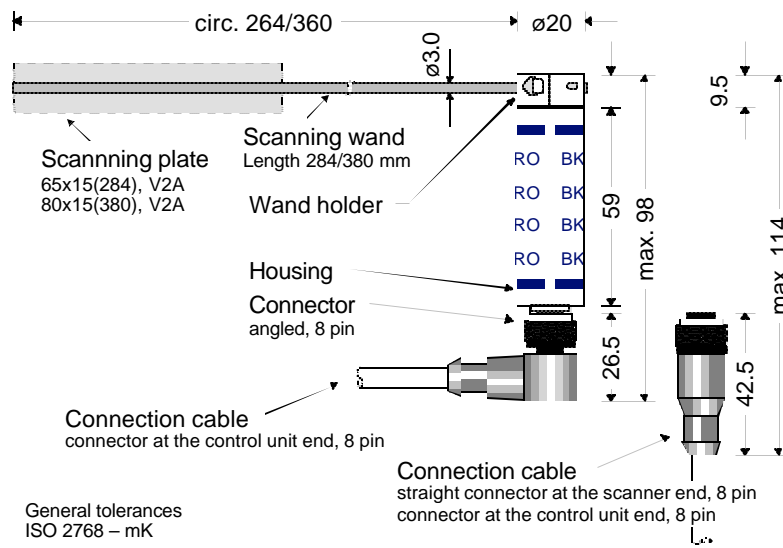

Fig. 2-3: Scanner

3 PROFIBUS-DP

3.1 Operating mode

BK MIKRO 8 PB can be employed in two operating modes.

- With PROFIBUS interface
- Operation about external switching inputs (without PROFIBUS)

If a tool (e.g. a drill) is to be checked, the control system calculates the corresponding angle of the scanning wand by the tool length stored in the tool database and transmit this value via PROFIBUS to control unit. After that the scanning can be started by the bit "Start".

If the scanning wand hits on of an object within the measuring range an O.K. message is output about the PROFIBUS, simultaneously is put also the exit (o.k.)

"Start" cycles with CW travel

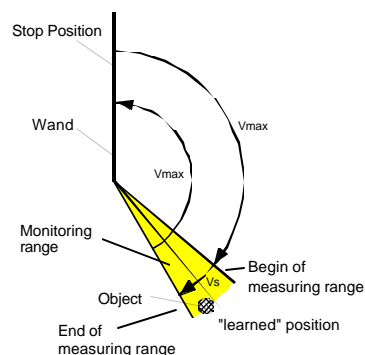

Monitoring range = learned (defaulted) position \pm tolerance

V_{max} = max. speed of scanning wand

V_s = speed of scanning wand preset by "Scanning intensity" toggle switch

If a tool is to be checked before its first use, this can be done using the angle set value as described above, or a teach traveling can be carried out. During learning cycle the angle set value is to be chosen greater than the actual value of the angle. Take care of this. The angle set value serves only as limit of the angle range during this cycle.

If the scanning wand hits on an object within the angular range, an O.K. message is triggered and kept on the reported measured angle about the PROFIBUS. This angle can be filed in the tool database to the corresponding tool. While checking the tool, the stored angle with a tolerance value is sending onto the control unit. With the bit "start" then is started the message.

Using "Go Position" the scanning wand can be moved to a position (tolerance $\pm 8^\circ$). The achieved position is transmitted via PROFIBUS.

3.2 Construction

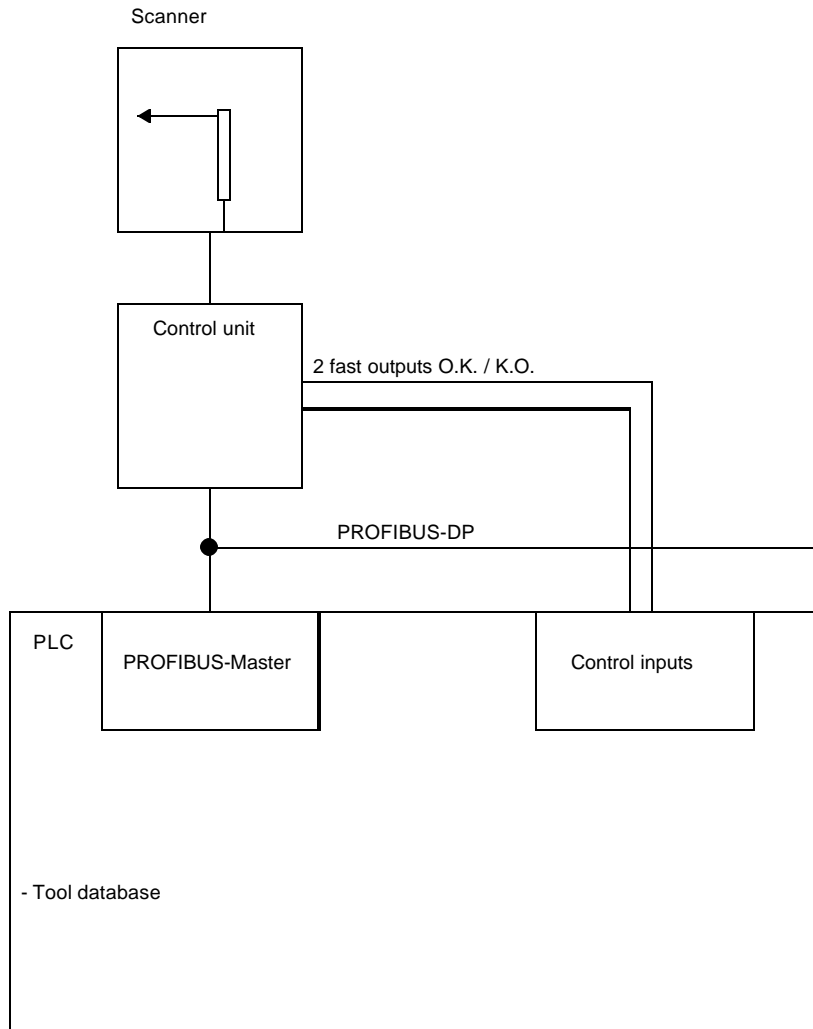

Fig. 3-1: Construction of a typical BK MIKRO 8 PB system

3.3 Electric design (Physical Layer)

3.3.1 Interface

The PROFIBUS interface is realized as a floating RS-485 interface (electrically insulated).

A standard 9 pin Sub-D socket is used for plug.

The pin assignment of the 9 pin Sub-D socket corresponds to PROFIBUS standard.

Sub-D socket, 9 pin	Pin	Signal	Function
	1	n.c.	not connected
	2	n.c.	not connected
	3	RxD/TxD-P	Data line B
	4	RTS	Request To Send
	5	GND	Data reference potential
	6	5V	5 VDC
	7	n.c.	not connected
	8	RxD/TxD-N	Data line A
	9	n.c.	not connected

Fig. 3-1: PROFIBUS-DP interface

Supported baud rates	
9.6	kbaud
19.2	kbaud
45.45	kbaud
93.75	kbaud
187.5	kbaud
500	kbaud
1.5	MBaud
3	MBaud
6	MBaud
12	MBaud

The baud rate is identified automatically.

3.3.2 LED's to indicate status information

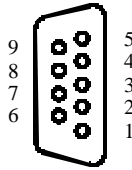
Four light-emitting diodes (LED's) on the front panel of the BK MIKRO 8 PB control board are used to indicate status information.

One LED is attached to PROFIBUS.

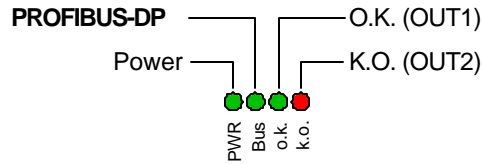

Fig. 3-2: Light-emitting diodes

LED	Color	Designation	Function	Status
Bus	green	PROFIBUS-DP (RDY)	Data transmission (RUN)	flashing
			PROFIBUS not active	out
PWR	green	Power	Power supply 24 VDC	on
o.k.	green	O.K. (OUT1)	Scanning "O.K."	on
k.o.	red	K.O. (OUT2)	Scanning "K.O."	on

3.3.3 Address setting

The PROFIBUS address is set in binary form by the 8 pin DIP switch S1 on the control board in the case interior.

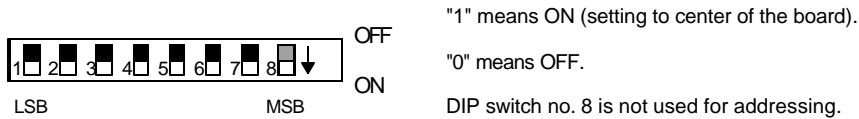

Fig. 3-3: DIP switch S1

Example:

DIP switch S1	Value of the DIP switch no.								Address
	1	2	3	4	5	6	7	(8)	
	1	0	0	1	0	0	0	X	9
	0	1	1	0	0	1	0	X	38
	0	0	1	1	1	1	1	X	124

Switch settings on delivery:

	0	1	0	0	1	1	0	X	50
--	---	---	---	---	---	---	---	---	----

3.4 Configuration

PLC → BK MIKRO 8 PB: 3 data words output (2 bytes each)

Output words		Function
AW1	Bit 0...7	Parameter identification
AW1	Bit 8...15	
AW2	Bit 0...7	Control word
AW2	Bit 8...15	
AW3	Bit 0...7	Angle set value
AW3	Bit 8...15	

BK MIKRO 8 PB → PLC: 3 data words input (2 bytes each)

Input words		Function
EW1	Bit 0...7	Parameter identification
EW1	Bit 8...15	
EW2	Bit 0...7	Status word
EW2	Bit 8...15	
EW3	Bit 0...7	Angle
EW3	Bit 8...15	

Data from PLC to BK MIKRO 8 PB control unit will be transmitted via control words of the PROFIBUS (process channel).

Data from BK MIKRO 8 PB control unit to PLC will be transmitted via status words.

Data transmission runs cyclically.

3.5 Process data: Output words 2 and 3

From PLC to BK MIKRO 8 PB control unit

Control word AW2

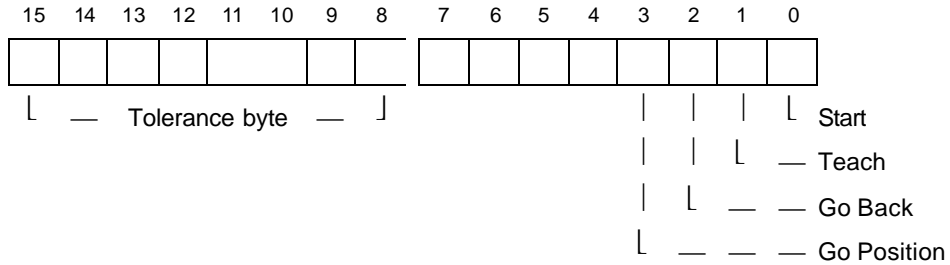

Tolerance byte		Tolerance: Specification of the angle in multiples of 0.1 degree [°]
Value	Degree [°]	
0	Param.	Accept value of parameter no. 5 (Tolerance range)
1	0.2	Not 0.1, but 0.2 (required precision)
2	0.2	
3	0.3	
...	...	
255	25.5	

Angle set value AW3

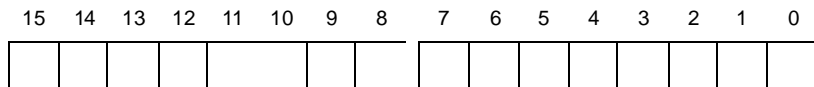

Angle set value		Angle set value: Specification of the angle in multiples of 0.01 degree [°]
Value	Degree [°]	
0	0	
1	0.01	
2	0.02	
3	0.03	
...	...	
65535	655.35	

Angle min. 8°: 320 hex = 0000 0011 0010 0000
 Angle max. 300°: 7530 hex = 0111 0101 0011 0000

3.6 Status words: Input words 2 and 3

From BK MIKRO 8 PB control unit to PLC

Status word EW2

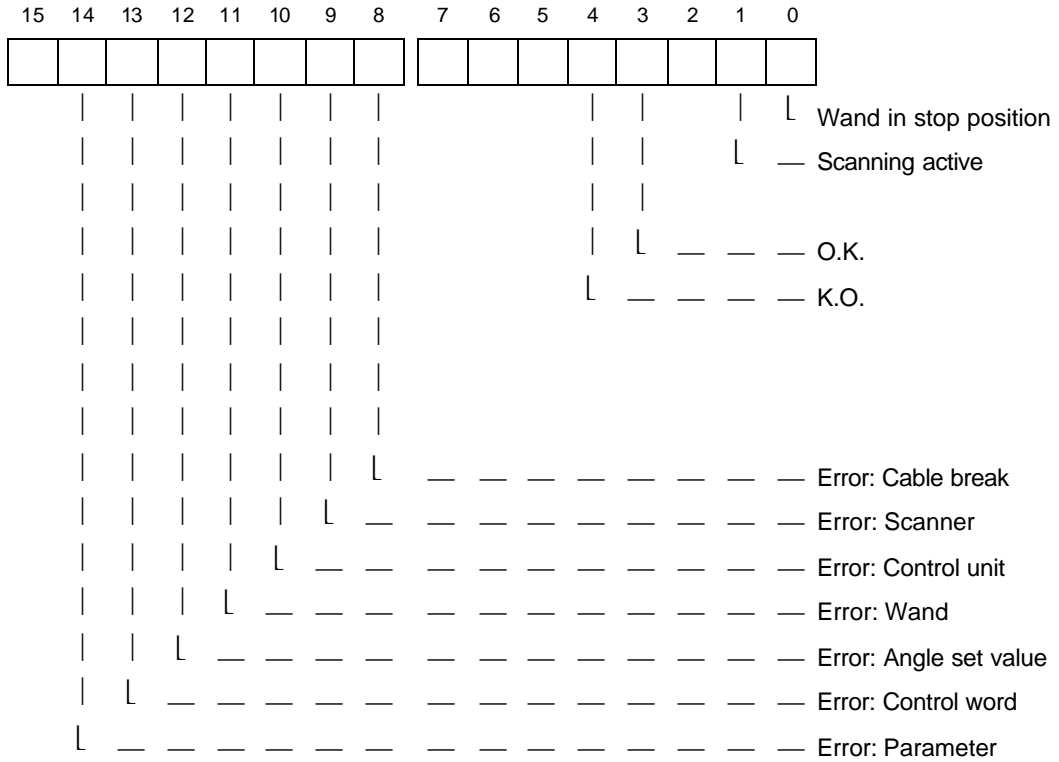

Angle EW3

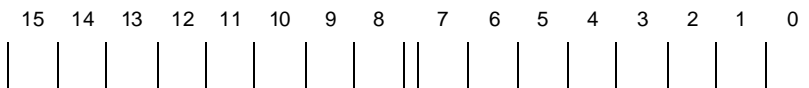

Angle	
Value	Degree [°]
0	0
1	0.01
2	0.02
3	0.03
...	...
65535	655.35

Angle: Specification of the angle in multiples of 0.01 degree [°]

3.7 Parameter

The transmission of the parameters runs also cyclically via the process channel of the PROFIBUS.

From PLC to BK MIKRO 8 PB control unit

Parameter identification AW1

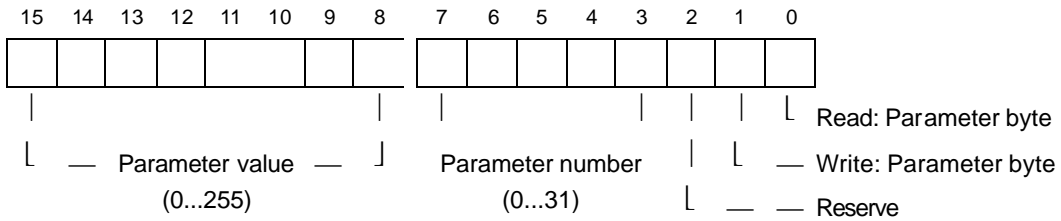

From BK MIKRO 8 PB control unit to PLC

Parameter identification EW1

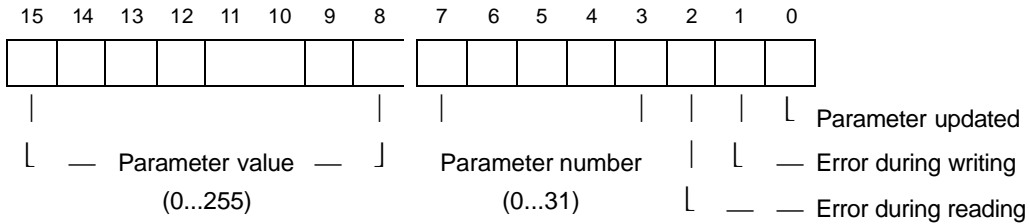

3.7.1 Parameter list

Number	Name	Default	Min.	Max.	Format	Description
0	Scanning intensity	0	0	1		0 = Low 1 = High
1	Out1 (O.K.) Relay output	1	0	1		0 = InActive normally closed 1 = Active normally open
2	Out2 (K.O.) Relay output	1	0	1		0 = InActive normally closed 1 = Active normally open
3	Monitoring	1	0	1		0 = Free space 1 = Object
4	Rotation direction	1	0	1		0 = Counter-clockwise 1 = Clockwise
5	Tolerance range	30	2	255	0.1° / unit	3.0° (Default)
6	Scanner	1	1	1		TK8A
7	P1 Low byte	0	0	255	0.01° / unit	Position 1
8	P1 High byte	18	0	255	2.56° / unit	46.08° (Default)
9	P2 Low byte	0	0	255	0.01° / unit	Position 2
10	P2 High byte	53	0	255	2.56° / unit	135.68° (Default)
11	Return travel monitoring	0	0	1		0: no effect to outputs. 1: If wand does not come back during return travel, K.O. output will be active.
12	Power On	1	0	1		0: Wand will not travel after Power On. 1: Wand will travel to stop position after Power On.
13						
14						
15						
16						
17						
18						
19						
20						
21						
22						
23						
24						
25						
26						
27						
28						
29	Date month	Read_only				Date month
30	Date year	Read_only				Date year

31	Version	Read_only		Software version
----	---------	-----------	--	------------------

Tab. 3-4: Parameter list

3.7.2 Declarations concerning parameters

The table shows the allocation of parameters 0 ... 31.

There are parameters that can be read and to which can be written, as well as read-only parameters that can only be read.

An attempt to write a read-only parameter causes an error message.

- Scanning intensity

Scanning intensity determines permissible force and permissible speed during learning cycle and/or within tolerance range of start cycle. There are two steps of setting.

- Out1 and Out2

Using these parameters relay output 1 (O.K.) and/or relay output 2 (K.O.) can be defined, as it will operate in the "active" state.

After switch-on these outputs are always on the set state "normally closed" or "normally open" without a scanning has occurred before.

- Monitoring

Using this parameter, monitoring mode can be set to object monitoring or free space monitoring.

- In case of object monitoring an object will be scanned, and if the object is detected in the defaulted area the O.K. output will be activated, or if the object is not detected the K.O. output will be activated.

- In case of free space monitoring it will be checked whether the predefined area can be scanned by the wand without detecting an obstacle.

This monitoring mode does not allow any learning cycle.

Monitoring ranges are defined either by angle set value and tolerance set value or by parameters position P1 and P2.

- For tolerance 0, +/- the parameter value "Tolerance range" is used as tolerance range.

- For angle set value 0, P1 and P2 are used as tolerance range.

- Rotation direction

Using this parameter the scanning direction can be changed.

As soon as the parameter is changed, the wand starts to the "new stop position" and will set a "new" reference position.

- Tolerance range

The tolerance range can be set by this parameter. With this information the tolerance range has not to be set in start cycle.

Tolerance range = 0 in control word: +/- parameter value is used as tolerance range.

- Scanner
Settings of the scanner (for further applications).
- Position 1: P1 Low byte, P1 High byte and
Position 2: P2 Low byte, P2 High byte
Using these parameters the angle set value can be preset by P1 and P2.
These values are used as range set value as soon as angle set value = 0.
- Return travel monitoring
Using this parameter the O.K. output can be activated in case of non-attaining the stop position. If return travel monitoring is not active, this information can also be interrogated in bit "Wand in stop position" via PROFIBUS.
- Power On
Using this parameter it can be prevented that the wand starts moving immediately after switch-on of the power supply.

Usually set parameter to 0: Default!

4 Installation Notes

4.1 Mounting bracket

The delivering program offers a mounting bracket for the scanner as accessories.

Article no. 61 07 165 contains the following parts:

Designation	Material	Part no.
Mounting bracket	AlCuMgPb, F 38, thickness 8, naturally anodized	1, 2
2 cheese head screws with hexagonal hole M3x40	8.8 zincd	3
2 self-securing nuts M3	8 zincd	4

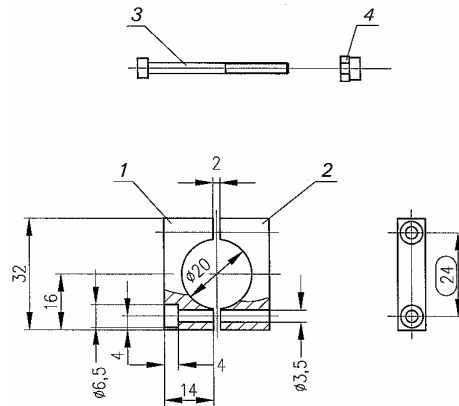

General tolerances ISO 2768 – mK
burred edges

Fig. 4-1: Mounting bracket

4.2 Interference prevention

All inputs are opto-decoupled and thus maximally protected against interference voltage peaks, as caused, for example, by inductive sources.

Relay outputs are protected by varistors against inductive interference voltage peaks. Depending on the type of load used, further interference suppression measures may be necessary.

To ensure optimum operational safety, suppression measures, if required, must be taken at the source, i.e. directly where interference is caused.



Possible additional noise filters:

- RC combination (included in the contactor suppliers' product ranges)
- Varistors
- Diodes

4.3 Tolerance Calculation:

Use the Angle (A) that you want the tolerance to be (the range is selectable between 0.2 and 25.5 degrees) multiply this by π and divide by 180. Take the answer and multiply by the length of the wand you will be using. This will give the \pm tolerance in inches or mm depending on which you used for the length of the wand.

$$A\pi/180 = \text{Answer}$$

$$\text{Answer} \times \text{Length} = \pm \text{Tolerance}$$

Appendix A**Model 8 Manufacturing and Techna-Tool Part Numbers**

<u>Mfg. Part Number</u>	<u>Techna-Tool Part Number</u>	<u>Description</u>
TK8A.xx	BK8SC	BK Mikro Model 8 Scanner
63 04 236	BK824-PROFI	BK Mikro Model 8 24V input Controller