

BK MIKRO 5-RL

Tool Monitoring System

Technical Documentation - North American Edition

Revision 2.0

Released: April, 1997



553 Industrial Dr. Hartland, WI 53029 262-367-8665 fax 262-367-0208
web-site www.techna-tool.com email techtool@techna-tool.com

Contents

1. DESCRIPTION	3
2. SYSTEM COMPONENTS	4
2.1. CONTROL UNIT	4
2.1.1. <i>Characteristic Properties</i>	4
2.1.2. <i>Technical Data</i>	5
2.1.3. <i>Scanner Socket</i>	5
2.1.4. <i>Screw Terminals</i>	6
2.1.4.1. Power Supply	7
2.1.4.2. Control Inputs	8
2.1.4.3. Relay Outputs	8
2.1.5. <i>Light-Emitting Diodes</i>	8
2.1.6. <i>Toggle Switches</i>	9
2.1.6.1. Switch "MODE 1"	9
2.1.6.2. Switch "MODE 2"	9
2.1.6.3. "Normally Open Contact/Normally Closed Contact" Switch	9
2.1.6.4. "Decel" Switch	9
2.1.7. <i>Notes on Technical Safety</i>	10
NO ISOLATION FROM DC POWER SUPPLY	10
2.2. SCANNER TK 5	11
2.2.1. <i>Characteristic Properties</i>	11
2.2.2. <i>Technical Data</i>	12
2.3. CONNECTION CABLE	12
3. FUNCTION	13
3.1. TEACH-IN	13
3.2. START	13
3.3. SCANNING TIMES	14
3.4. STATUS INDICATION	14
3.4.1. <i>Yellow LED</i>	14
3.4.2. <i>Red/Green LED</i>	14
3.5. DEFLECTION OF WAND	14
4. INSTALLATION NOTES	15
4.1. CONTROL VOLTAGE CONNECTION	15
4.2. ELECTRICAL INTERFERENCE PREVENTION	16
Appendix A Model 5 Manufacturing and Techna-Tool Part Numbers	16

© Copyright 1997, Techna-Tool Inc., Hartland, Wisconsin, and MSC Tuttlingen GMBH i.Gr., Tuttlingen, Germany.

The information in this document is subject to change without notice.

1. Description

BK MIKRO 5-RL is a tool monitoring system customized for simultaneous scanning of two tools.

The complete BK MIKRO 5-RL system comprises

- a control unit,
- a sensing head (scanner),
- a connection cable.

Principle of Operation

The system will monitor the presence of two particular tools. The monitoring system will first determine the exact position of the tools by a "teach-in" cycle. This cycle is followed by sensor-mode, during which the sensing wand will be moved to the positions "just learned", and a comparison takes place.

All output to the machine will be via two relay contacts, configurable as normally closed or normally open. For machine control, the "O.K." relay, the "K.O." relay, or both may be used.

The zero position of the wand will be calculated during the "teach-in" cycle from the positions of the two objects to be scanned. Starting from this position, any desired scanning angle can be implemented.

Further features enabling customized system configuration include:

- Automatic detection of zero position (point of reference between scanning positions), or manually established rest position.
- Relay contacts switch-selectable as normally open or normally closed.
- Two settings of controlled acceleration and deceleration.
- Detection of cable breaks.

2. System Components

2.1. Control Unit

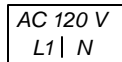
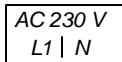
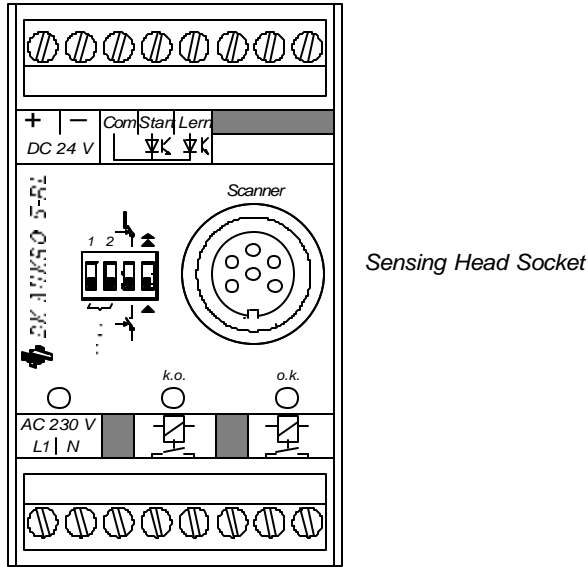

Supply Voltage
(optional)

2.1.1. Characteristic Properties

The BK MIKRO 5 system control unit is housed in an insulating material housing. On its front panel, the control unit is fitted with screw terminals to connect all machine inputs and outputs, supply voltage, and the scanner.

Note:

The unit is available in three different models for three different supply voltages: 24 VDC, 120 VAC, 230 VAC.

2.1.2. Technical Data

Housing.....	Insulated Material Housing, Protection Class II
Protection Type.....	IP 20
Dimensions (W x H x D)	45 mm x 75 mm x 107.5 mm
Case Mountings	DIN Rail, 35 mm, to DIN EN 50022
Power Supply Voltage.....	Depending on Model: 24 VDC 120 VAC 230 VAC
Power Consumption.....	6 VA max.
Control Voltage	24 VDC (internal/external)
Inputs.....	Galvanically Isolated
Switched Outputs.....	2 x 250 VAC / 30 VDC
Making/Breaking Capacity.....	500 VA / 60 W (max.) 10 mA min. at 10 V
Operational Life of Relay	5×10^7 switching cycles
Connections.....	- Scanner socket to DIN 45322, 6 pins - plug-in screw terminals for connecting - power supply - control inputs - relay outputs - scanner
Temperature Range	0°C to +50°C

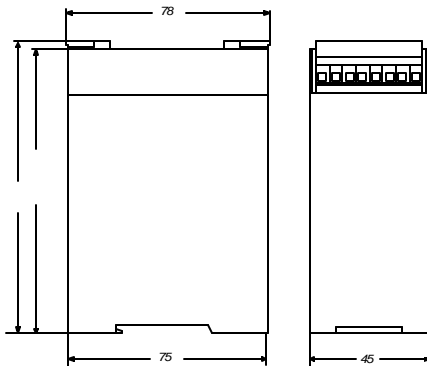
**2.1.3. Scanner Socket**

For connecting scanner TK5, a 6 pin socket to DIN 45322 is fitted on the control unit front panel.

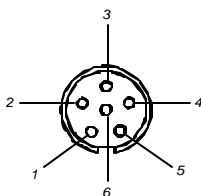
**Note:**

Using a different scanner may damage and/or destroy scanner and control unit.

2.1.4. Screw Terminals

The screw terminals have been arranged on two plug-in terminal blocks. These blocks are keyed so that they cannot be accidentally plugged into the wrong socket. When in operation, plastic caps cover the screws in the front. Wires to be connected are routed from the top or bottom of the unit. Power supply, control inputs, relay outputs, and the scanner are all connected via these screw terminals.

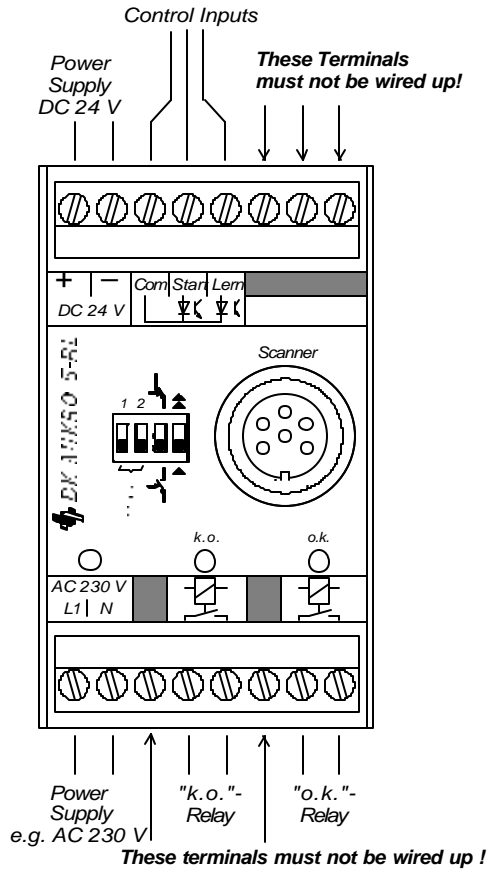

Note:

These plugs may only be inserted or removed when the power supply has been disconnected.

Unmarked terminals must not be connected.

2.1.4.1. Power Supply

"24 VDC" Model

- Terminal "+" 24 VDC
Supply Voltage Input 24 VDC \pm 20%
Input Current 0.25 A max.
- Terminal "-" 24 VDC
Reference potential of 24 VDC supply voltage.

"120 VAC" and "230 VAC" Models

Depending on the specific model, the unit will be supplied preconfigured for "120 VAC" or "230 VAC". The relevant version will be marked on the unit type plate next to the supply connections on the front panel.

- Terminals "L1" and "N"
Supply Voltage Input, depending on model:
120 VAC ($I_{\max} = 0.05$ A) or
230 VAC ($I_{\max} = 0.025$ A)
- Terminal "+" 24 VDC
Control voltage output for controlling inputs "Start" and "Learn," 24 VDC (16 V ... 32 V) unregulated.
The control voltage meets the requirements for an extra low function potential with safe disconnection.
Output Current 0.1 A max.
If an external control voltage is applied, this terminal is not connected.
- Terminal "-" 24 VDC
When using the internal control voltage, this terminal must be connected to the control inputs terminal "Com".
If an external control voltage is applied, this terminal is not connected.

Note:

Alternatively, "120 VAC" and "230 VAC" models may also be supplied with 24 VDC. In this case, terminals "L1" and "N" must not be connected. Terminals "+24 V" and "-24 V" are to be connected as described above for "24 VDC" model.

2.1.4.2. Control Inputs

- "Com" Terminal

Reference potential for control inputs

- "Start" Terminal

An input level of +24 VDC will trigger a "sensing" cycle.

The input current is approximately 5 mA; pulses lasting less than 6 ms will be disregarded.

- "Lern" Terminal

An input level of +24 VDC will trigger a "learning" cycle (the "teach-in").

The input current is approximately 5 mA; pulses lasting less than 6 ms will be disregarded.

The position stored during the learning cycle will remain stored even after the unit has been switched off. Therefore, a new "teach-in" session is required only when your tool geometry changes, or the scanner is changed.

2.1.4.3. Relay Outputs

The terminals have been designed as dry relay contacts. By switch selection, they may be configured as either normally open or normally closed. (Note that when using the relays as normally closed, the contacts will be open when there is no power to the unit.) The contacts have been designed for 250 V and protected against inductive switch-off peaks of up to 19 W (2 ms).

Maximum switching power is 500 VA.

Maximum switching current may not exceed 2 A.

- "K.O." Relay Terminals

These two terminals are used to indicate a fault message (K.O.).

- "O.K." Relay Terminals

These two terminals are used to indicate a good cycle (O.K.).

2.1.5. Light-Emitting Diodes

Three light-emitting diodes on the front panel inform users about the current status of their BK MIKRO 5-RL monitoring system:

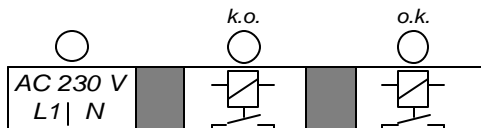

- Power Supply / Status
yellow LED to indicate supply voltage or status
- "K.O." Relay
red LED to indicate fault message
- "O.K." Relay
green LED to indicate no fault message

2.1.6. Toggle Switches

Using the four toggle switches arranged next to each other on the control unit front panel, the following functions may be set.

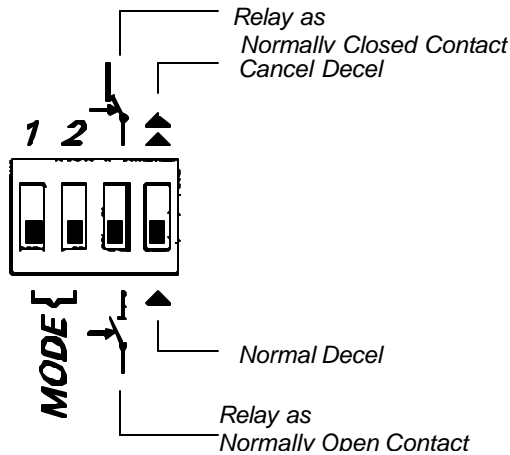

Note - Setup on Delivery:

All switches are toggled downwards.

2.1.6.1. Switch "MODE 1"

The "MODE 1" switch determines how the home position is located. With the switch in the "off" or "down" position, the unit will automatically set the home position as being halfway between the two tool positions. If the switch is in the "on" or "up" position, the unit will use the position that the wand is in when the learn cycle is initiated as its home position.

2.1.6.2. Switch "MODE 2"

The switch "MODE 2" has been reserved for future new features, and does not have any function at this time.

2.1.6.3. "Normally Open Contact/Normally Closed Contact" Switch

The "Normally Open Contact/Normally Closed Contact" switch determines the mode of operation for the two output relays.

2.1.6.4. "Decel" Switch

The "Decel" switch determines whether the scanner will slow down while in its scanning range.

Note:

For normal tool detection applications, this switch should be in the "Normal Decel" position, as the normal deceleration of the unit is designed to protect the unit from wear and tear.

2.1.7. Notes on Technical Safety

The control unit comprises the following **circuits, all isolated** from each other:

K.O. Output (2 terminals)	safely isolated from all other circuits
O.K. Output (2 terminals)	safely isolated from all other circuits
AC power supply (L1, N)	safely isolated from all other circuits
DC power supply (+24 V, -24 V)	safely isolated from K.O. output, O.K. output, and AC power supply simply isolated from control inputs no isolation from scanner connections
Control Inputs (Com, Start, Lern)	safely isolated from K.O. output, O.K. output, and AC power supply simply isolated from DC power supply and scanner connections
Scanner Connections	safely isolated from K.O. output, O.K. output, and AC power supply simply isolated from control inputs no isolation from DC power supply

2.2. Scanner TK 5

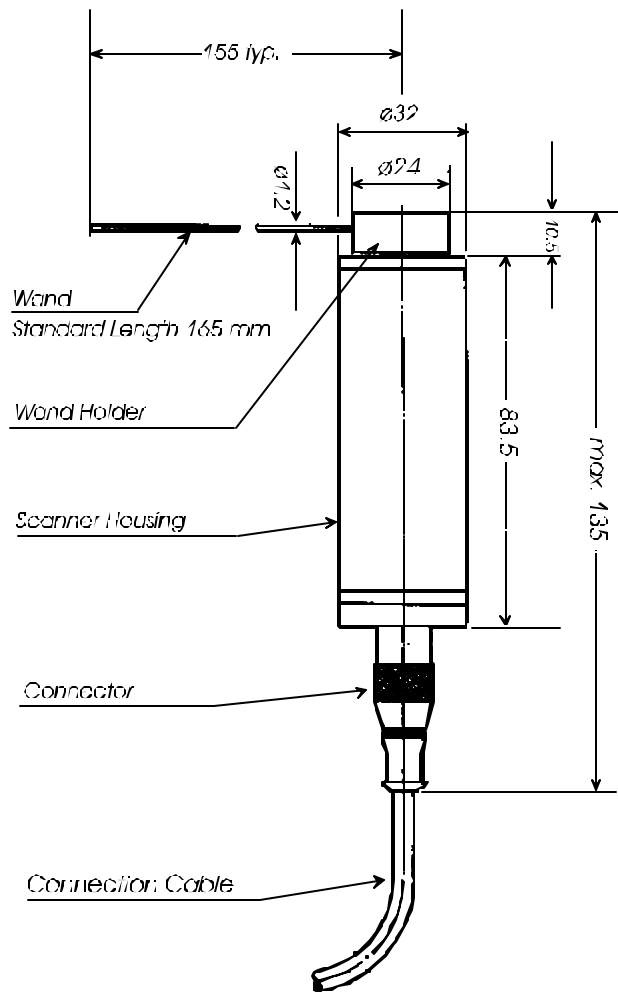

Note: A right angle cable connector is available for applications with limited clearance behind the scanner.

2.2.1. Characteristic Properties

The scanner housing is cylindrical and smooth, thus permitting easy installation, e.g. using a collet chuck. The scanner is designed for easy access for servicing and changing the wand.

Aligning the scanner is easy and requires no additional instruments or aids. The wand is to be positioned at random between the two objects to be monitored. Its "teach-in" cycle will determine the respective positions of these objects, calculate zero position as the center between the two tools and move the wand into this position.

Note:

Using scanner TK 5 with a different control unit than BK MIKRO 5-RL may damage and/or destroy scanner and control unit.

Your wand is a wearing part!

Each contact with a rotating object will cause corresponding wear on the wand. This may even lead to the metal wand breaking. Due to the injury hazard this causes, users should exercise particular caution within any BK MIKRO 5-RL rotating area.

2.2.2. Technical Data

- Housing.....Anodized Aluminum
- Protection Type.....IP 67
- Wand Length.....165 mm (standard)
- Scanning Angle.....± 180°
- Control Unit ConnectionConnector, M12x1, 6 pins
- Temperature Range.....0°C to +80°C
- Sensing Cycles.....> 10 million with normal decel

Option: Wand Holder for Small Chips

If BK MIKRO 5 is used to monitor manufacturing processes where materials with small chips are processed (e.g. cast iron, diecast aluminum, brass), we recommend the use of our specially designed wand holder for this purpose.

2.3. Connection Cable

Control unit and scanner are connected by a 6-wire PUR-cable:

- connector to DIN 45322 at the control unit end
- molded plug at the scanner end
- length 5 m, can be extended to a maximum length of approximately 25 m.

Pin Configuration (at the control unit end)

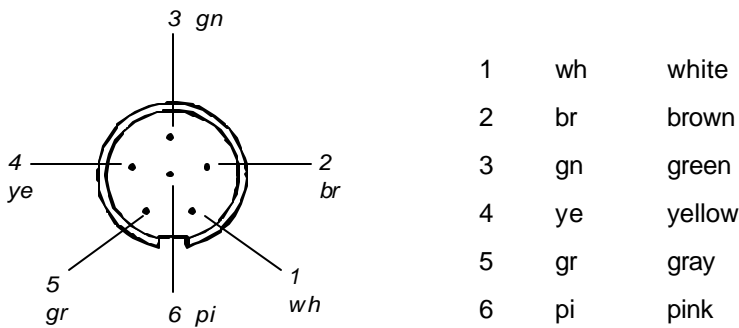

If this plug needs to be removed during fitting, please ensure that this pin configuration is followed on reassembly.

Note:

To avoid unnecessarily reducing the operational life of this cable, it should not be subject to more than a minimum amount of movement during operating cycles.

3. Function

3.1. Teach-in

The "teach-in" cycle will be started by an active input signal on the "Learn" terminal. Both relay outputs for "O.K." and "K.O." will become inactive. The wand will first travel **in clockwise direction**. If a tool is detected, its position will be stored. The wand will then travel **in counter-clockwise direction** to determine the position of the second tool. The position of this second tool will also be stored.

- Using both positions, the system will calculate the new zero position for the wand, which is the mathematical center of the two learned positions (if switch "MODE 1" is down), or the location of the wand at the beginning of the teach-in cycle (if switch "MODE 1" is up). Finally, the wand will move into its newly calculated zero position. In addition, the "O.K." relay will be activated and indicated on the "O.K." LED.
- In the event of a faulty learning action, the "K.O." relay will activate, the "K.O." LED lights up. The wand will return into its old position. Subsequent starts will be ignored.

Note:

A position learned during "teach-in" will remain stored, even after removal of power to the unit.

Ensure that tool geometry (layout and dimensions) at "teach-in" corresponds to the geometry used during monitoring in the "Start" mode.

3.2. Start

A "Start" cycle will be triggered by an active input signal on the "Start" terminal. Both relay outputs for "O.K." and "K.O." will become inactive.

The wand will travel to the previously "learned" positions of the objects to check for their presence. In so doing, the wand will first travel in a clockwise direction.

- If both tools are in their "correct" positions, the "O.K." relay will be activated. Angle tolerance for a no fault message (O.K.) is $\pm 10^\circ$ in relation to the learned position.
- If one of the two tools is not detected, i.e. either it is missing or there is an obstacle within the wand rotating area, the "K.O." relay will be activated.

In addition, the light-emitting diodes on the control unit will indicate the result.

3.3. Scanning Times

Depending on the length of the path to be traveled, different scanning times will result. Several test series produced the following typical results:

Angle	Measuring Time	Scanning Time
± 15°	300 ms	300 ms
± 180°	1200 ms	1200 ms

This shows: Scanning time = measuring time

3.4. Status Indication

3.4.1. Yellow LED

Fast Flashing = Self-Test

After power-up, the system will carry out a self-test indicated by fast flashing of this yellow LED.

Steady Illumination = Ready to Operate

Following its self-test, the system is ready to operate. The LED stops flashing and remains steady.

Slow Flashing = Motor Fault / Cable Break

The system has detected a motor fault or cable break. Outputs will be switched inactive, the unit will remain in its present state, indicated by slow flashing of this yellow LED.

3.4.2. Red/Green LED

Steady Illumination = Indication following Scanning Cycle

The red LED indicates a fault message.

The green LED indicates a no fault message.

3.5. Deflection of Wand

Rotation angles will be detected by scanner encoder pulses. These pulses are derived from the rotation of the motor. For scanning, a metal needle (wand) is used which, depending on the scanning force, can be deflected. As the scanner motor is still turning when the end of this wand has already come to a stop, differences between the set and actual rotation ranges will result.

For all speeds, wand deflection is compensated to a range of less than 10°. Deflection will depend, however, on wand length.

4. Installation Notes

4.1. Control Voltage Connection

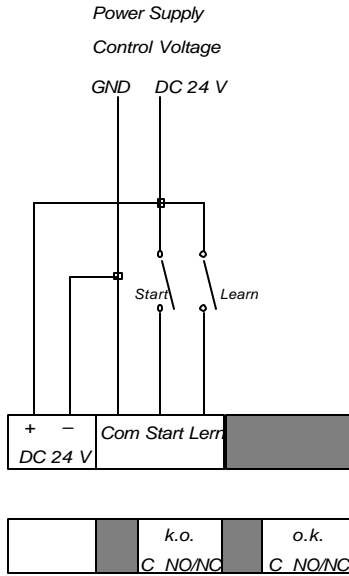

BK MIKRO 5-RL
DC 24 V
common power and control voltage supply

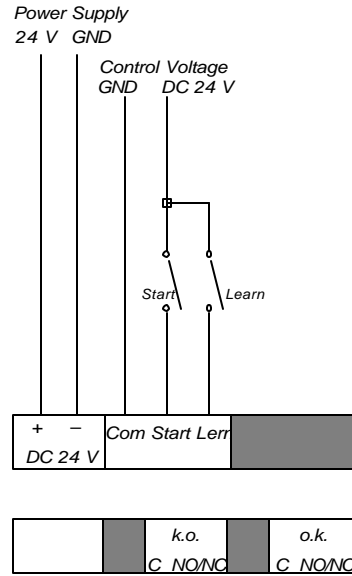

BK MIKRO 5-RL
DC 24 V
separate control voltage

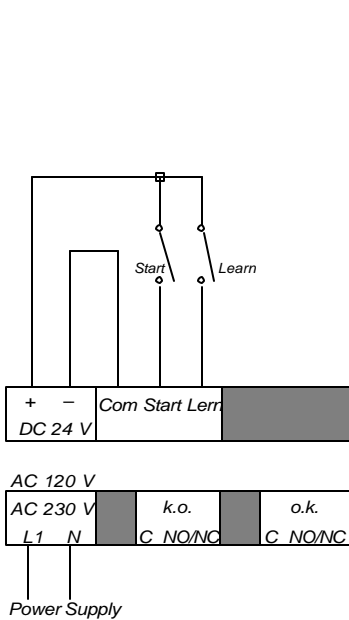

BK MIKRO 5-RL
AC 230 V (AC 120 V)
internal control voltage

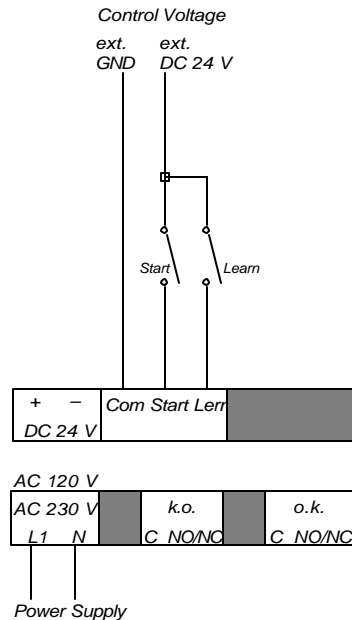

BK MIKRO 5-RL
AC 230 V (AC 120 V)
external control voltage

4.2. Electrical Interference Prevention

All inputs are opto-decoupled and thus maximally protected against interference voltage peaks, as caused, for example, by inductive sources.

Relay outputs are protected by varistors against inductive interference voltage peaks. Depending on the type of load used, further interference suppression measures may be necessary.

To ensure optimum operational safety, suppression measures, if required, must be taken at the source, i.e. directly where interference is caused.

Possible additional noise filters:

- RC combination (included in the contactor suppliers' product ranges)
- Varistors
- Diodes

Appendix A

Model 5 Manufacturing and Techna-Tool Part Numbers

COMPLETE SYSTEMS:

BK5 110 AC Volt System **BK5110S**
 (Includes BK5SC, BK5110, BK5C5 and BKMB)

BK5 24 DC Volt System **BK524S**
 (Includes BK5SC, BK524, BK5C5 and BKMB)

COMPONENTS:

	<u>Model #</u>	<u>Description</u>
<u>Scanner:</u>	BK5SC	Scanner (TK5K.xx)
<u>Controller:</u>	BK5110	110 Volt AC (8.0502.xx, 6304202)
	<i>Note:</i>	<i>BK5110 works with 110 or 24V</i>
	BK524	24 Volt AC (8.0503.xx, 6304207)
<u>Cable:</u>	BK5C5	5 meter length
<u>Bracket:</u>	BKMB	Mounting Bracket 50mm sq. (2" Square)

ACCESSORIES

<u>Cables:</u>	BK5C5R	5 meter length w/ rt. angle
	**BK5C10	10 meter length cable
	**BK5C15	15 meter length cable
	**BK5C20	20 meter length cable

** Right angle connectors are available.

Extension Cables - (must be used with cable BK5C5 or BK5C5R above)

	BK5EC5	5 meter length
	BK5EC10	10 meter length
	BK5EC15	15 meter length

Mounting Bracket: BKMB 50 mm sq. (2 inch sq.)

Delivery: 1-5 systems normally from stock / 6 or more 2-4 weeks