

TECHNA-CHECK[®] Model 100-L

Tool Monitoring System

Technical Documentation - North American Edition

Revision 1.1

Released: June, 1997



TECHNA-TOOL & MACHINE CO. INC.

553 Industrial Dr. Hartland, WI 53029 262-367-8665 fax 262-367-0208

web-site www.techna-tool.com email techtool@techna-tool.com

Contents

1. THE CONCEPT 3

2. KEY BENEFITS 3

3. FUNCTION 4

3.1. GENERAL 4

3.2. LEARN SIGNAL 5

 3.2.1. *Learn Cycle Initiation -- Machine Controlled* 5

 3.2.2. *Learn Cycle Initiation -- Face Plate* 5

 3.2.3. *Learn Cycle Initiation -- TMSMON* 5

3.3. FAULT SIGNALS AND RESETTING OF FAULTS 5

3.4. ANALOG ZOOM FUNCTION 6

3.5. MISSING TOOL SUPERVISION 7

 3.5.1. *Missing Tool -- Absolute Mode* 7

 3.5.2. *Missing Tool -- Learn Work Mode* 8

3.6. TOOL BREAK SUPERVISION 9

 3.6.1. *Break Mode Selection* 9

 3.6.2. *Tool Break -- Absolute Peak Mode* 9

 3.6.3. *Tool Break -- Learn Peak Mode* 10

3.7. BLUNT TOOL SUPERVISION 11

 3.7.1. *Blunt Mode Selection* 11

 3.7.2. *Blunt Tool - Peak Mode* 12

 3.7.3. *Blunt Tool - Learn Peak Mode* 13

 3.7.4. *Blunt Tool - Work Mode* 14

 3.7.5. *Blunt Tool - Learn Work Mode* 15

3.8. IDLE POWER MONITORING 16

4. PROGRAMMING AND DISPLAY 17

4.1. DISPLAY 17

4.2. LOCKING AND UNLOCKING 17

4.3. PRIMARY MONITORING LIMITS AND TIMERS 17

4.4. PARAMETER MODE 18

5. INSTALLATION NOTES 21

5.1. MECHANICAL MOUNTING 21

5.2. ELECTRICAL CONNECTION 21

 5.2.1. *Power* 21

 5.2.2. *Control Inputs* 21

 5.2.3. *Control Outputs* 21

 5.2.4. *Analog Output* 21

6. RATINGS AND SPECIFICATIONS 23

6.1. MECHANICAL 23

6.2. ELECTRICAL 23

© Copyright 1997, Techna-Tool & Machine Co. Inc., Hartland, Wisconsin, USA, and Hydria Elektronik ApS, Vodskov, Denmark.

The information in this document is subject to change without notice.

TECHNA-CHECK® is a registered trademark of Techna-Tool & Machine Co. Inc.

1. THE CONCEPT

The TECHNA-CHECK® Model 100-L measures and displays true electrical power consumption (kW). The power calculated is true electrical power, including AC power factor, given by the formula:

$$P = \sqrt{3} VI \cos Q \text{ (AC Mode)}$$

The TECHNA-CHECK® Model 100-L has been exclusively developed for the **supervision of cutting tools on single spindle automatic machine tools. It is capable of detecting missing, blunt, and broken or damaged tooling.** The TECHNA-CHECK® Model 100-L measures the electrical power consumption of the spindle motor. A blunt (or worn) tool needs more energy to complete a machining cycle, and when a tool breaks a short energy peak or spike is created. If no tool is present, the power consumption drops back to the idle power of the spindle.



2. Key Benefits

Improved part quality

The detection of missing or broken tools helps insure that the proper machining is being performed. Detection of tool wear and damage can help improve surface finish and tolerances.

Maximized tool life

By detecting for tool wear and damage, expensive tooling can be changed before the damage gets too severe. This detection also reduces dependence on hit or miss part counting schemes.

Protection of spindle and feed mechanism

By detecting catastrophic tool failures, the TECHNA-CHECK® Model 100-L can prevent serious damage to your head and feed mechanisms, not just at the station being monitored, but at down-stream stations where "chain reaction" effects can occur.

Improved up time

By creating the process improvements listed above, TECHNA-CHECK® Model 100-L keeps your machine running longer.

Easy installation

No mechanical modification of the machinery is necessary. The entire system mounts easily in your electrical cabinet.

3. Function

3.1. General

Figure 1 shows typical power consumption on a machine spindle during a machining cycle. The first power peak, which is caused by a change in motor speed or a motor start, is not monitored at all. Only the portion of the cut where the spindle speed is constant and the tool is actually in cut is monitored by the unit. When the machine head begins to move towards the part, a "Start" Signal is generated by the machine which tells the TECHNA-CHECK® Model 100-L that a new cycle is beginning. When the unit receives the start signal, the green Start LED is illuminated, and the user-defined Start Delay, T_s , is activated.

Figure 1 -- Function

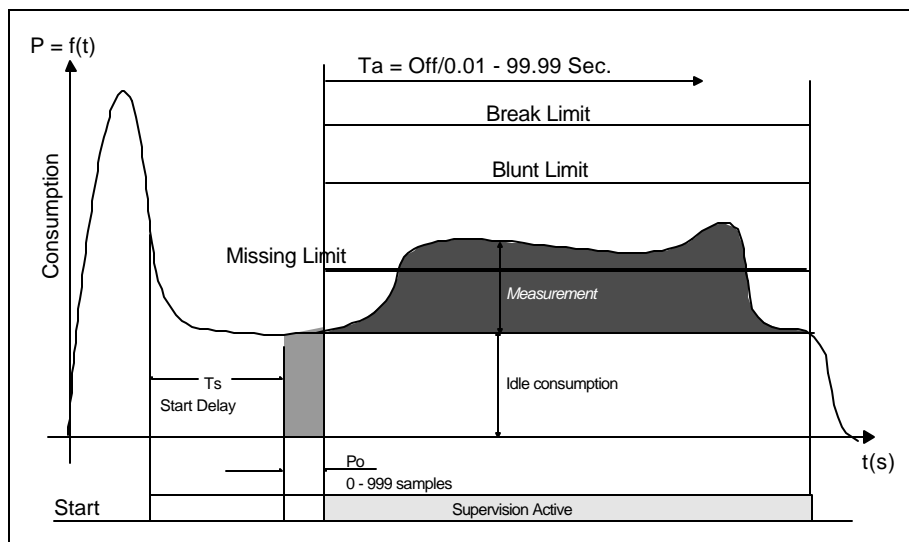

When the start delay ends, the unit initiates the idle power measurement. It is very important to measure the idle power **before** the tool begins cutting the part. The **idle power consumption, P_o** , is the portion of work done by the machine not going into the cut. Idle power consumption will vary normally during the course of the day due to such factors as friction, temperature, oil and grease viscosity, etc. The idle power is calculated as an average of a number of power measurements taken over a user-defined number of half electrical cycles (in North America, there are 60 electrical cycles per second). The number of samples (half electrical cycles) used to calculate the idle power is user set as the value of **P_o Averaging**, Parameter 4 (refer to "Parameter Mode," below). Minimum and maximum values of Idle Power, P_{oMin} and P_{oMax} (Parameters 21 and 22) may be set.

After the idle power measurement, the tool monitoring becomes active, and the green Active LED is illuminated. The duration of monitoring may be limited through the use of the monitoring timers, **T_a and T_w** (Parameters 10 and 11), in order to avoid monitoring undesired events, such as motor speed changes. In many cases, these timers may be turned off, allowing monitoring for as long as the start signal is present. The TECHNA-CHECK® Model 100-L includes a user programmable **Power Averaging** (Parameter 6) feature, which sets the number of individual power measurements which are averaged into one calculated value (again, the number of power measurements are related to the frequency of the supply power). This averaging can be used to "smooth" very noisy electrical signals, but it should be set as low as possible in order not to filter out very short duration power surges caused by tooling problems. The TECHNA-CHECK® Model 100-L includes a unique **Analog Zoom Function**, which greatly improves the monitoring of small tools. Refer to the section on "Analog Zoom Function" for details.

3.2. Learn Signal

For each type of monitoring (Missing, Break, and Blunt), there are one or more “Learn” modes available. The Learn modes allow the monitoring to change to take into account variations in tool grind from one tool to the next. In most applications, when using Learn modes, a Learn cycle should be initiated whenever the tool is changed. A Learn cycle may be initiated in three ways, as described below. It should be noted that during a Learn cycle, only Idle Power monitoring is taking place.

3.2.1. Learn Cycle Initiation -- Machine Controlled

A Learn cycle may be initiated by the machine controller. If the Start signal is made active while the Reset signal is being held active, the cycle will be a Learn cycle. If an Idle Power fault would occur during the Learn cycle, the reset signal must be taken low, then brought back high again to reset the fault.

3.2.2. Learn Cycle Initiation -- Face Plate

A Learn cycle may be initiated from the keyboard on the face plate of the unit. With the system unlocked (refer to “4.2. Locking and Unlocking” on Page 17), the MODE key is pressed once. The display shows “OFF”. To initiate the Learn cycle, one of the arrow keys is pressed, causing the display to show “ON”. The next cycle will be a Learn cycle.

3.2.3. Learn Cycle Initiation -- TMSMON

A Learn cycle may be initiated from the TMSMON software package by pressing the appropriate function key.

3.3. Fault Signals and Resetting of Faults

All faults generated by the TECHNNA-CHECK® Model 100-L are signaled to the machine controller by normally closed dry contact relays (refer to the section on “Electrical Connection”). The Tool Break and Tool Missing faults share a common relay. It is typical that the machine will be programmed to stop its present cycle immediately and retract the machine head on detection of a Tool Missing or Tool Break condition. The Blunt Tool fault is signaled by a second relay. It is typical that the machine will be programmed to finish the current cycle before stopping the machine on a Blunt Tool fault.

All faults may be reset by using the RESET button located on the front panel of the unit, or through the use of the external Reset input (refer to the section on “Electrical Connection”). The fault relays will remain in their active (open) condition until a reset is received.

3.4. Analog Zoom Function

Prior to setting the monitoring parameters, it is desirable to set up the **Analog Zoom Function** parameters. The Analog Zoom Function enables the TECHNA-CHECK® Model 100-L to monitor even very small tools by "focusing" the unit's full analog to digital conversion resolution into a narrow band of power consumption. To set the parameters, it is most helpful to use the TMSMON support software (see below). Note that the Analog Zoom Function should be set up prior to setting monitoring parameters, as the monitoring parameters will be "re-scaled" if changes are made to the Analog Zoom.

The **Current Range** (Parameter 15) must first be set. This parameter adjusts the overall scaling that the unit will use. Smaller values of Current Range will cause the unit to expand the power more. This parameter should be set so that the cutting torque is at least 5% to 10% higher than idle. Once the Current Range has been set, then any large idle powers may be subtracted from the display by adjusting **P1Min** (Parameter 14) so that the idle is only 5% to 10% of the full load. **P1Max** (Parameter 13) may then be adjusted so that the cutting torque is a rise of 10% to 20% above idle.

Figure 2 shows a hypothetical application to highlight the power of the Analog Zoom Function. In this application, a 380 VAC, three phase motor is being monitored. If the Current Range is set to 10 A, then 100% power is equivalent to 6.58 kW. If a small tool with a high spindle speed is being used, it is entirely possible that the idle power may be as high as 50% of the scale, while the cutting torque may only rise 2% or 3%. In order to maximize the ability to monitor this application, P1Min is "zoomed" to 50%, while P1Max is "zoomed" to 60%. The entire resolution of the unit is now concentrated in a 10% band. The unit is now only monitoring between 3.29 kW and 3.95 kW. The cutting torque will appear to be 10 times bigger.

Figure 2 -- Analog Zoom Function

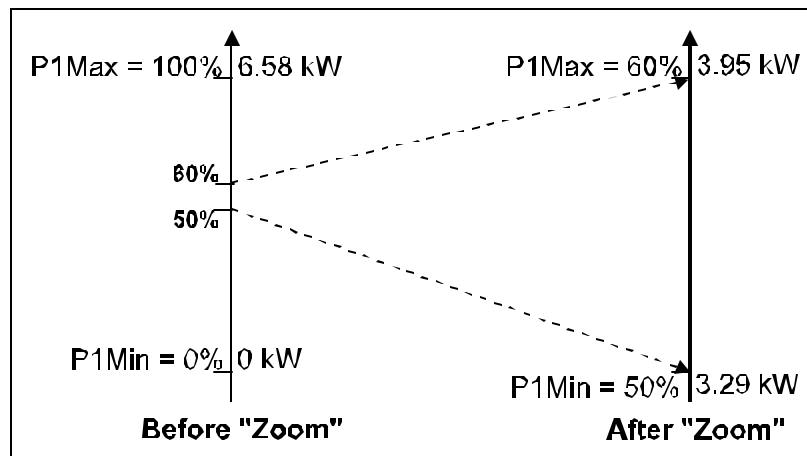

3.5. Missing Tool Supervision

3.5.1. Missing Tool -- Absolute Mode

Figure 3 shows how the missing tool detection, absolute mode, is set up relative to a typical machining cycle. The **Missing Mode**, parameter 5, defines the type of **Missing Tool Limit** which will be set. In the **Absolute mode**, the Missing Tool Limit is a user-defined absolute torque rise above idle. The power consumption during the machining cycle must remain above the limit for a cumulative time longer than the **Missing Delay**, T_{rm} . (Note that the cumulative nature of this measurement means that brief power dips below the Missing Limit will not cause a fault as long as the TOTAL amount of time spent above the Missing Limit is greater than the Missing Delay.) The red Missing LED is lit whenever the power is greater than the Missing Limit, until the Missing Delay has been satisfied. In the event of a missing tool fault, the red Missing LED will flash. Missing Tool supervision remains active for the entire time, following the Start Delay and idle power measurement, that the Start Signal is present if the monitoring timer T_w is turned off, or for the duration of T_w if it is enabled.

Figure 3 -- Tool Missing Absolute Mode

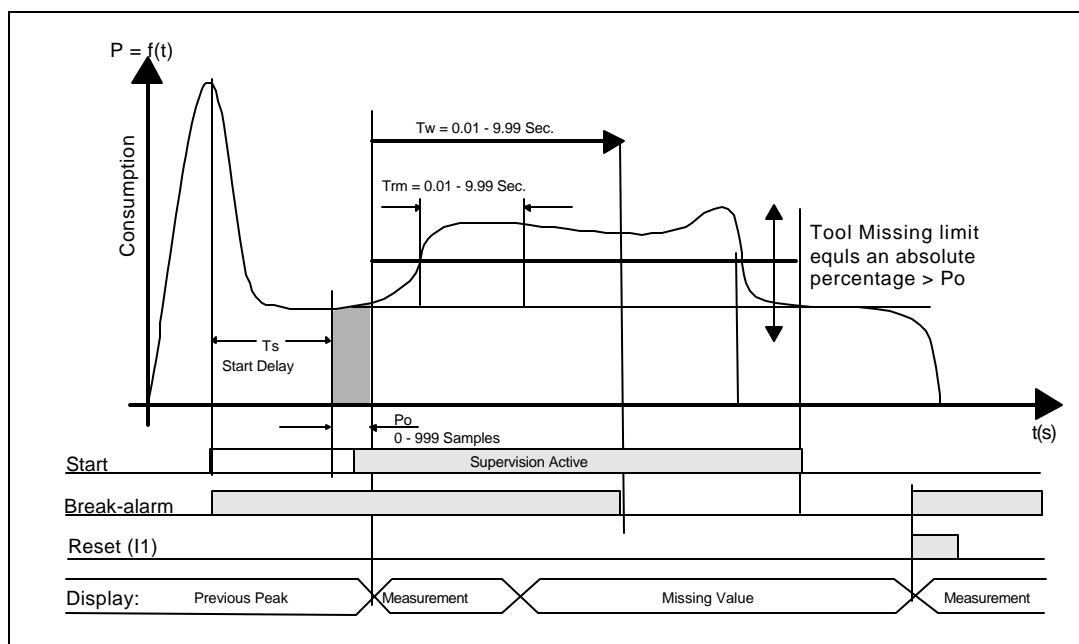

In determining appropriate values for the Missing Limit and Missing Delay, more aggressive monitoring can be achieved with higher Missing Limits and longer Missing Delays (in other words, for a good cycle, the power must stay higher longer). However, setting these parameters too aggressively can result in more frequent nuisance trips. A good compromise and starting point for adjustment seems to be to set the Missing Limit fairly low, around 3 - 5 % (since if the tool is missing, there will be NO rise above idle), and to set a Missing Delay of about 3/4 of the total machining time. Better results seem to be achieved by leaving the Missing Limit low, and tuning out nuisance trips by adjusting the Missing Delay.

3.5.2. Missing Tool -- Learn Work Mode

Figure 4 shows how the missing tool detection, Learn Work mode, is set up relative to a typical machining cycle. In the **Learn Work mode**, the Missing Tool Limit is a user-defined relative percentage of the work calculated during the Learn cycle. If the work calculated during a cycle does not exceed this percentage of the learned work, then a Missing alarm is generated. The red Missing LED is lit until the Missing Limit has been reached. In the event of a missing tool fault, the red Missing LED will flash. Missing Tool supervision remains active for the entire time, following the Start Delay and idle power measurement, that the Start Signal is present if the monitoring timer T_w is turned off, or for the duration of T_w if it is enabled.

Figure 4 -- Tool Missing Learn Work Mode

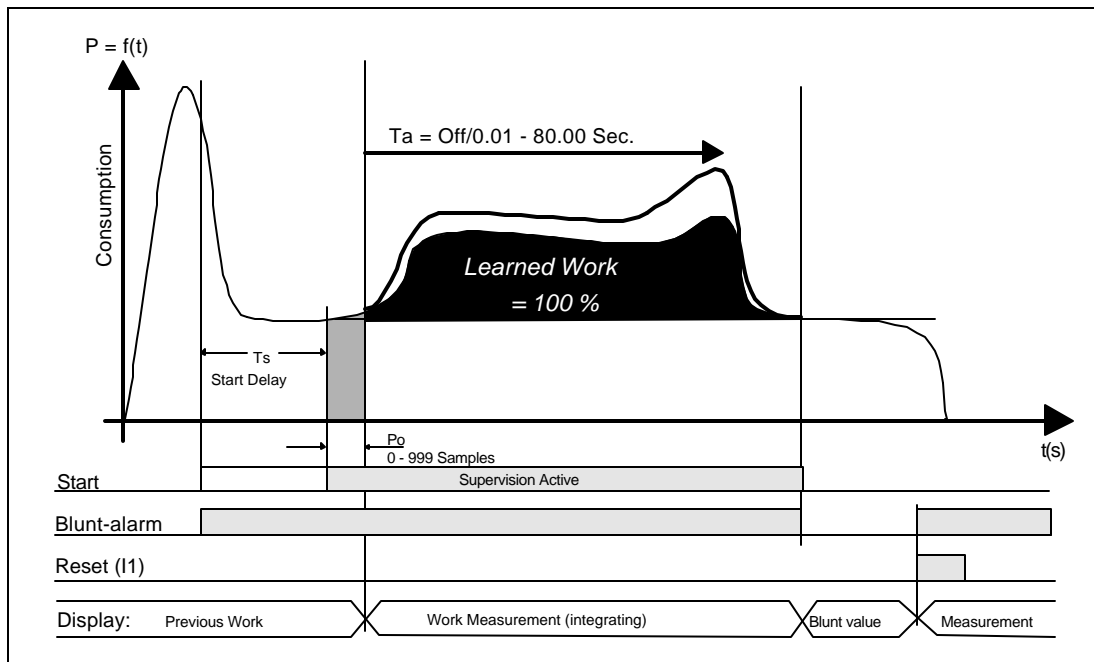

In determining appropriate values for the Missing Limit and Missing Delay, more aggressive monitoring can be achieved with higher Missing Limits and longer Missing Delays (in other words, for a good cycle, the power must stay higher longer). However, setting these parameters too aggressively can result in more frequent nuisance trips. A good compromise and starting point for adjustment seems to be to set the Missing Limit fairly low, around 3 - 5 % (since if the tool is missing, there will be NO rise above idle), and to set a Missing Delay of about 3/4 of the total machining time. Better results seem to be achieved by leaving the Missing Limit low, and tuning out nuisance trips by adjusting the Missing Delay.

Important Note: Due to display limitations, all monitoring based on Work calculations have a maximum cycle length of approximately 30 seconds. Cycles longer than 30 seconds will cause an overflow error.

3.6. Tool Break Supervision

3.6.1. Break Mode Selection

When a tool breaks while it is machining a part, it is typical to notice a sharp, short duration "spike" of torque in the motor. This torque spike is the extra energy being used by the machine to actually break the tool. The TECHNNA-CHECK® Model 100-L can detect this spike, and indicate a broken tool. (It should be noted that not all tools break the same way every time, and that a torque spike may not necessarily be generated in the process of breaking the tool. In this case, a missing tool condition should be noticed on the following cycle.)

There are two **Break Modes** available (Parameter 20), **Absolute Peak Mode**, and **Learn Peak Mode**, which are described below.

3.6.2. Tool Break -- Absolute Peak Mode

Figure 5 shows a typical tool break situation, including the setting of the tool **Break Limit**. The Break Limit is a user-defined percentage increase above the Idle Power. If the Break Limit is exceeded for a cumulative time greater than the user-defined **Break Delay**, T_{rb} , then a tool break fault will be generated. The red Break LED is illuminated whenever the measured power is above the Break Limit, and flashes whenever a Tool Break alarm is generated. Tool Break supervision remains active for the entire time, following the Start Delay and idle power measurement, that the Start Signal is present on the unit if monitoring timer T_a is turned off, or for the duration of T_a if it is enabled.

Figure 5 -- Absolute Peak Break Mode

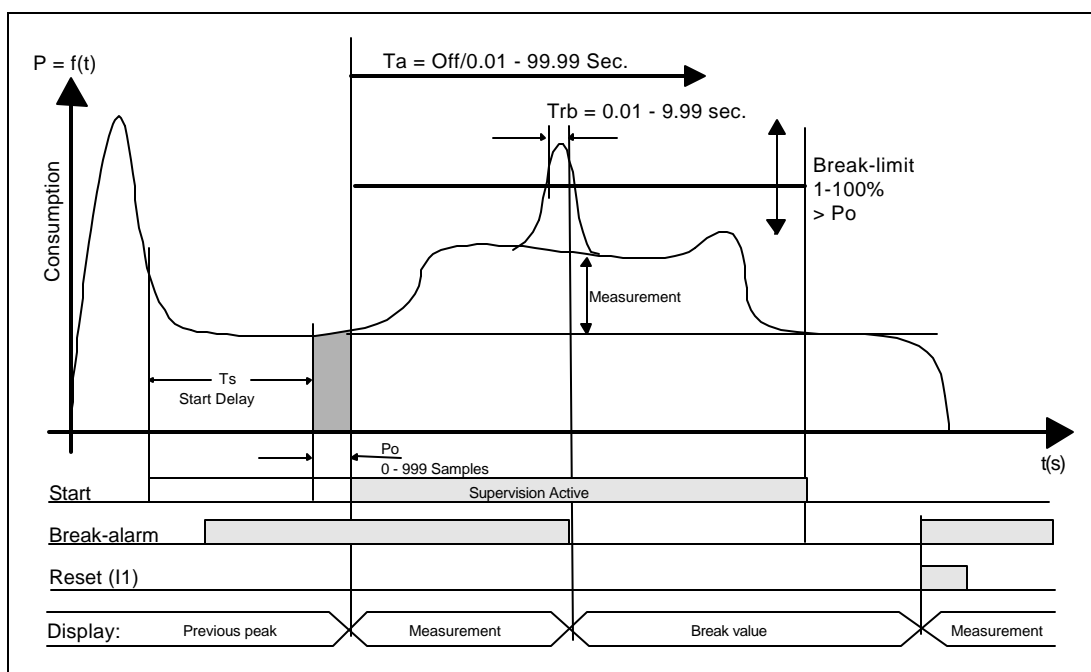

In setting the Break Limit and Break Delay, more aggressive monitoring is achieved by setting a lower limit and shorter delay. However, setting these parameters too aggressively will result in increased nuisance trips. In typical applications, the Break Limit is set fairly high (between 25 and 50%), but with a very short Break Delay (often the minimum 0.01 second). When a tool break occurs, the rise in torque is often quite dramatic, so a high limit and short delay would be best to eliminate nuisance faults.

3.6.3. Tool Break -- Learn Peak Mode

Figure 6 shows a typical tool break situation, including the setting of the tool **Break Limit** in Learn Mode. The Break Limit in Learn Mode is a user-defined percentile increase of the power consumption above the Idle Power PLUS the Learned peak power. If the Break Limit is exceeded for a cumulative time greater than the user-defined **Break Delay, Trb**, then a tool break fault will be generated. The red Break LED is illuminated whenever the measured power is above the Break Limit, and flashes whenever a Tool Break alarm is generated. Tool Break supervision remains active for the entire time, following the Start Delay and idle power measurement, that the Start Signal is present on the unit if monitoring timer Ta is turned off, or for the duration of Ta if it is enabled.

Figure 6 -- Learn Peak Break Mode

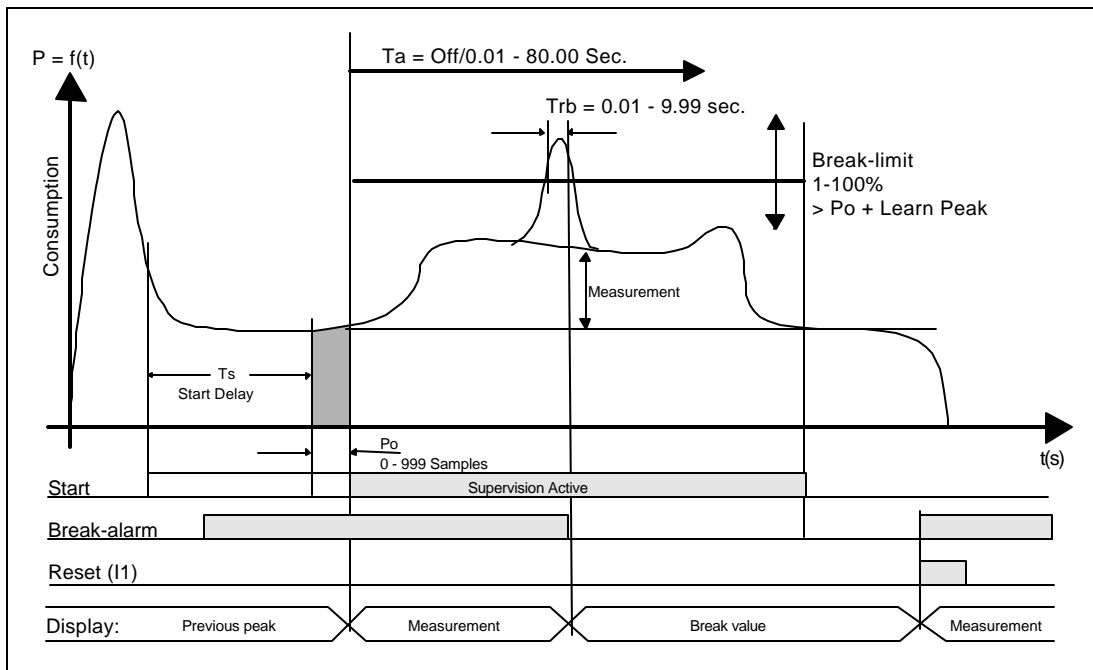

Setting the Break Limit and Break Delay in Learn Mode is much the same as in the Absolute Peak Mode, except that the Break Limit in Learn Mode will “move” with respect to the learned cut. This adaptation allows the unit to adjust to changes in grind from one tool to the next.

3.7. Blunt Tool Supervision

3.7.1. Blunt Mode Selection

As a tool wears, it is normal for its cutting surfaces to become less efficient, and thus it requires more torque to cut the part. The TECHNNA-CHECK® Model 100-L is designed to look for this rise in torque, and to stop the machine when a tool has reached a point where it would be desirable to change it.

There are four **Blunt Modes** (Parameter 18). If **Absolute Peak Mode** is selected, the detection of blunt tools is based on the value of the instantaneous torque measurement above idle. In **Absolute Work Mode**, the detection of blunt tools is based on the area under the torque curve for the duration of the cutting cycle, which is proportional to the work or energy used to cut the part. Peak Mode is recommended for most simple machining operations. Work Mode may be used when there are multiple or changing load levels observed during the cycle, such as when a step tool or complicated boring tool is used. Additionally, there are two Blunt Modes representing **Learn** versions of the two mode already described. They allow the system to automatically adjust to changes in grind from one tool to the next.

In any blunt mode, the use of the **Show Statistics** option from the TMSMON software package is helpful in setting appropriate values for the **Blunt Limit**. When a computer running TMSMON is connected to the TECHNNA-CHECK® Model 100-L, it is continually keeping track of the peak torque or work used in each cycle. This data may be viewed in the Show Statistics display. This display will give you an idea, over time, of how the tool has worn, and where an appropriate Blunt Limit may be set.

Also in any blunt mode, the **Blunt Counter** (Parameter 12) feature is available. In order to reduce the number of undesired nuisance trips, the Blunt Counter may be set to require a number of consecutive blunt tool faults to be detected before the machine is signaled to stop. For example, a hard part or temporary chip build up may cause a blunt fault to occur in one cycle, but the condition may not be present again in the next cycle. In this case, a Blunt Counter setting of, for example, three would require this condition to occur three cycles in a row before a blunt trip stops the machine. In typical applications, a Blunt Counter setting from 2 to 5 is generally used, depending on material consistency and chip build-up, but higher settings may be used.

3.7.2. Blunt Tool - Peak Mode

Figure 7 shows a typical blunt tool situation using Peak Mode monitoring, including the setting of the tool **Blunt Limit**. The Blunt Limit is a user-defined percentage increase above the Idle Power. If the Blunt Limit is exceeded for a cumulative time greater than the user-defined **Blunt Delay, Trs**, then a tool blunt fault will be generated. The red Blunt LED is illuminated whenever the measured power is above the Blunt Limit, and flashes whenever a Blunt Tool alarm is generated. Blunt Tool supervision remains active for the entire time, following the Start Delay and idle power measurement, that the Start Signal is present on the unit if monitoring timer T_a is turned off, or for the duration of T_a if it is enabled.

Figure 7 -- Peak Blunt Mode

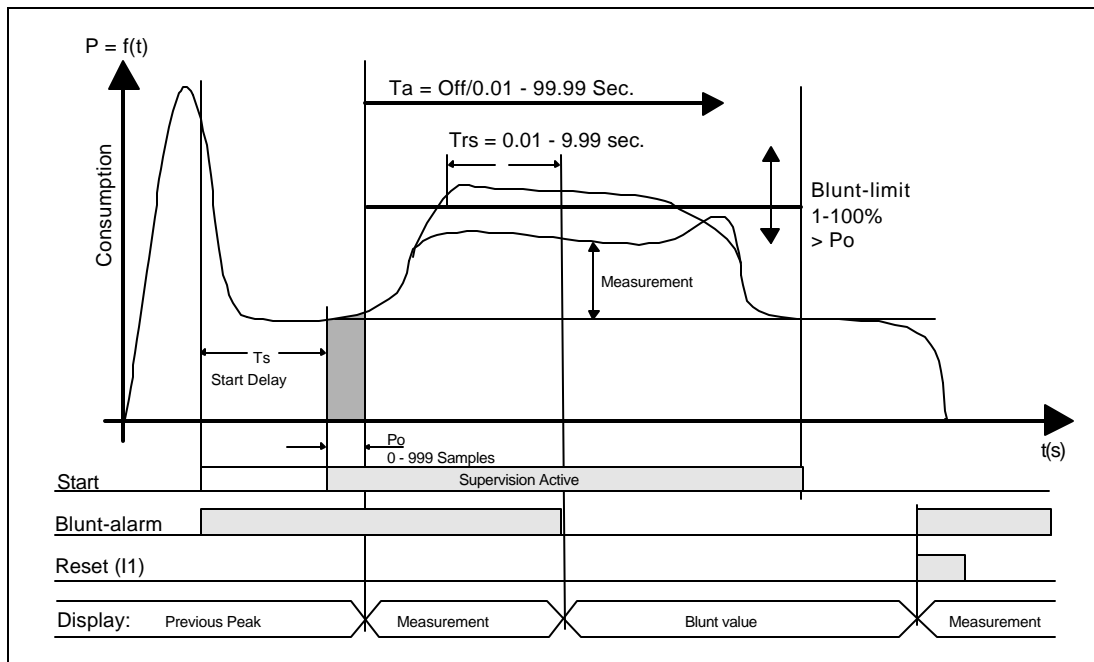

When using Peak Mode, the **Blunt Alarm Mode** (Parameter 19) may be set to cause a trip either at the **End** of the cycle, or **Immediate** upon detection.

In setting the Blunt Limit and Blunt Delay, more aggressive monitoring is achieved by setting a lower limit and shorter delay. However, setting these parameters too aggressively will result in increased nuisance trips. As a tool wears, the load will gradually increase, and will eventually stay at a higher level for the entire duration of the cut. In typical applications, the Blunt Limit is set fairly low (between 10 and 25%), but with a fairly long Break Delay (often around 75% of the total duration of the cut). Adjustments are then made based on data from the Show Statistics display, usually leaving the Blunt Delay alone, but changing the Blunt Limit.

3.7.3. Blunt Tool - Learn Peak Mode

Figure 8 shows a typical blunt tool situation using Learn Peak Mode monitoring, including the setting of the tool **Blunt Limit**. The Blunt Limit is a user-defined percentile increase above the Idle Power PLUS the Learned Peak. If the Blunt Limit is exceeded for a cumulative time greater than the user-defined **Blunt Delay**, T_{rs} , then a tool blunt fault will be generated. The red Blunt LED is illuminated whenever the measured power is above the Blunt Limit, and flashes whenever a Blunt Tool alarm is generated. Blunt Tool supervision remains active for the entire time, following the Start Delay and idle power measurement, that the Start Signal is present on the unit if monitoring timer T_a is turned off, or for the duration of T_a if it is enabled.

Figure 8 -- Learn Peak Blunt Mode

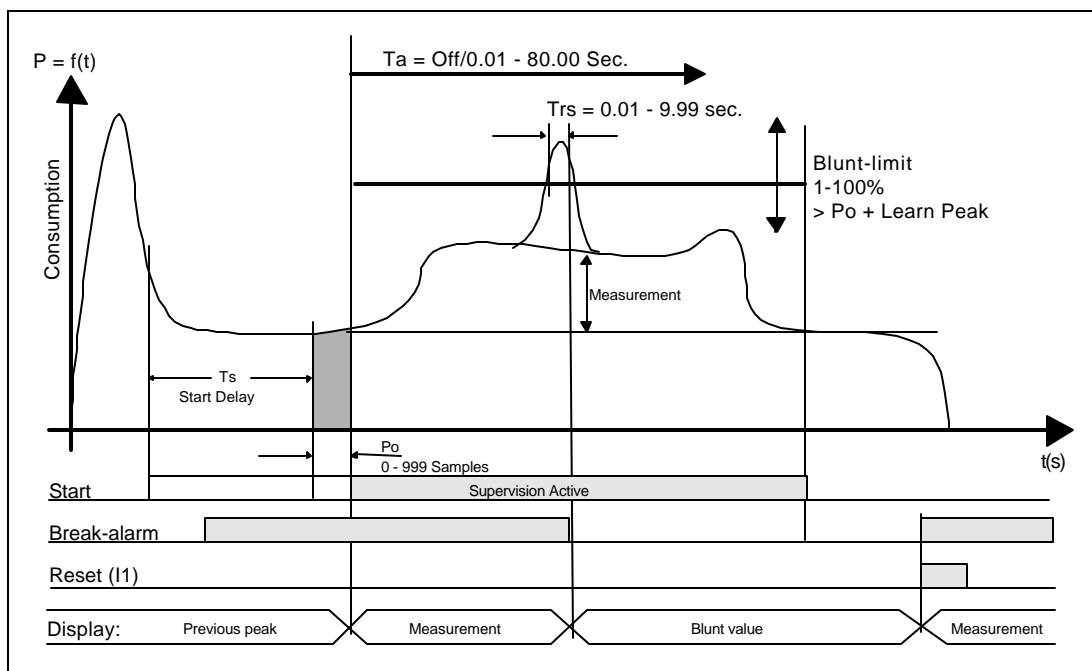

When using Learn Peak Mode, the **Blunt Alarm Mode** (Parameter 19) may be set to cause a trip either at the **End** of the cycle, or **Immediate** upon detection.

Setting the Blunt Limit and Blunt Delay in Learn Peak Mode is much the same as setting them in regular Peak Mode. The addition of the Learn function means that the monitoring limit will automatically adjust for variations in grind from tool to tool.

3.7.4. Blunt Tool - Work Mode

Figure 9 shows a typical blunt tool situation using Work Mode monitoring, including the setting of the tool **Blunt Limit**. The work, or energy consumed, during the cutting cycle is proportional to the black area in the Figure. The Blunt Limit is a user-defined energy level, not including the Idle Power consumed. If the Blunt Limit is exceeded, then a tool blunt fault will be generated (note that the Blunt Delay becomes inactive in Work Mode). The red Blunt LED flashes whenever a Blunt Tool alarm is generated. Blunt Tool supervision remains active for the entire time, following the Start Delay and idle power measurement, that the Start Signal is present on the unit if monitoring timer T_a is turned off, or for the duration of T_a if it is enabled. Because Work Mode monitoring calculates total energy used in the entire cycle, any faults will always be signaled at the end of the cycle.

Figure 9 -- Work Blunt Mode

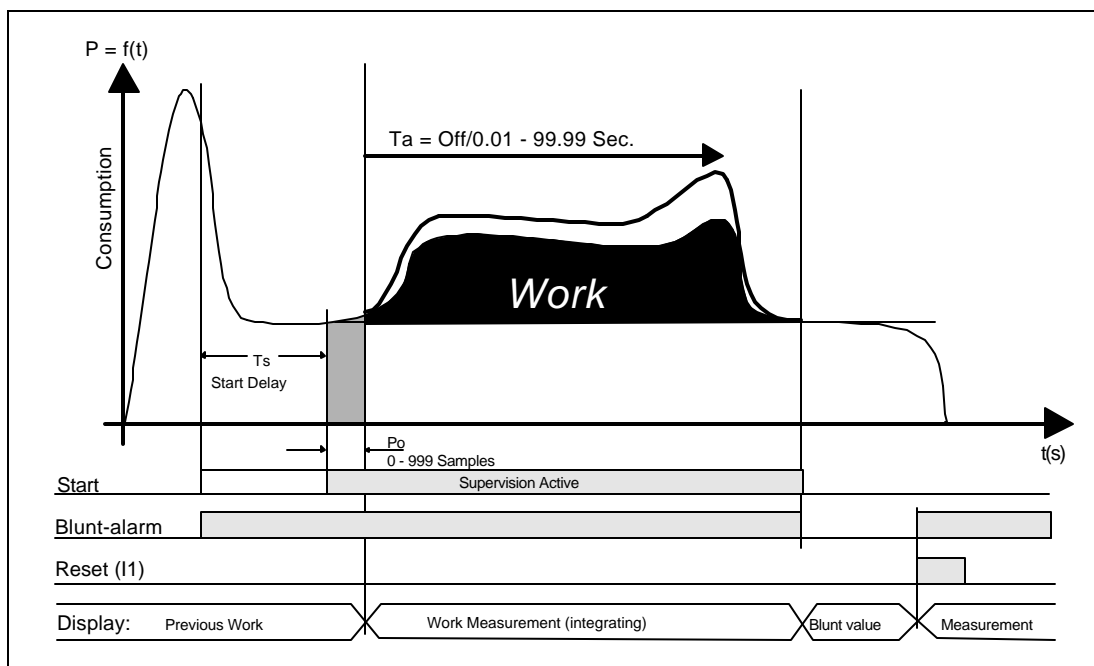

In setting the Blunt Limit in Work Mode, more aggressive monitoring is achieved by setting a lower limit. However, setting this parameter too aggressively will result in increased nuisance trips. When Work Mode is selected, the **Part Count** display in the TMSMON software automatically changes to a work level for the previous cycle. In typical applications, a setting for the Blunt Limit of about 10 to 25% above the work level of a new tool should be a good starting point. The use of the Show Statistics option from TMSMON should help in setting a final value.

Important Note: Due to display limitations, all monitoring based on Work calculations have a maximum cycle length of approximately 30 seconds. Cycles longer than 30 seconds will cause an overflow error.

3.7.5. Blunt Tool - Learn Work Mode

Figure 10 shows a typical blunt tool situation using Learn Work Mode monitoring, including the setting of the tool **Blunt Limit**. The work, or energy consumed, during the cutting cycle is proportional to the black area in the Figure. The Blunt Limit is a user-defined percentage increase above the Learned Work. A fault is generated if the measured work exceeds the percentage increase over the Learned Work (note that the Blunt Delay becomes inactive in Work Mode). The red Blunt LED flashes whenever a Blunt Tool alarm is generated. Blunt Tool supervision remains active for the entire time, following the Start Delay and idle power measurement, that the Start Signal is present on the unit if monitoring timer T_a is turned off, or for the duration of T_a if it is enabled. Because Work Mode monitoring calculates total energy used in the entire cycle, any faults will always be signaled at the end of the cycle.

Figure 10 -- Learn Work Blunt Mode

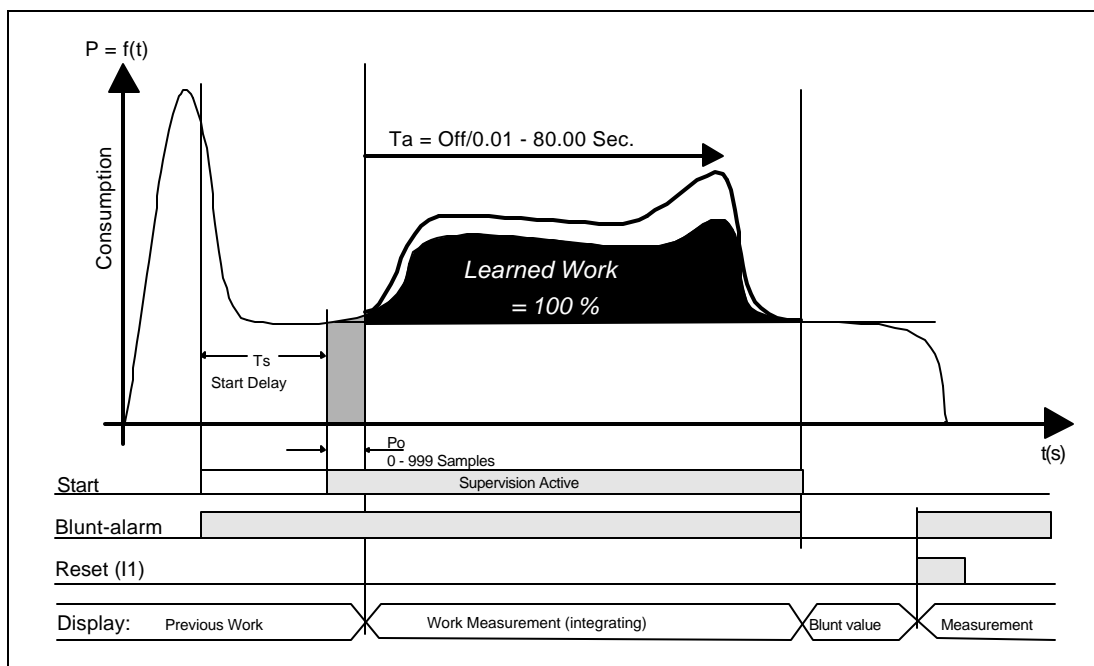

Setting the Blunt Limit in Learn Work Mode is much the same as setting the limit in regular Work Mode. The Learn feature gives the system the ability to adjust monitoring for differences in tool grind from one tool to the next.

Important Note: Due to display limitations, all monitoring based on Work calculations have a maximum cycle length of approximately 30 seconds. Cycles longer than 30 seconds will cause an overflow error.

3.8. Idle Power Monitoring

In some applications, it may be necessary to check that the machine idle power is within certain boundaries. For example, a very low idle power may indicate that a belt is broken or that there is no power to the motor. A very high idle power may also indicate belt problems, or problems with lubrication or bearings. In these cases, a high and low limit, PoMax and PoMin (Parameters 22 and 21), for the idle power may be set. After the idle power is measured and Po is calculated, the value is compared with PoMax and PoMin. If it is not within the limits, then a Tool Break fault occurs immediately.

Each of the Idle Power Monitoring limits may be disabled by turning them all the way down to zero.

4. Programming and Display

4.1. Display

During normal system operation, the display on the front of the unit will show the instantaneous power being used while the system is receiving a Start Signal from the machine. After the Start Signal ends, indicating that monitoring should stop and the machining is finished, the display will show the maximum power measured during the cycle. The appearance of the display may be adjusted through the use of two parameters. The first, **Display Resolution** (Parameter 7), adjusts how many decimal digits are displayed. The second, **Refresh Delay** (Parameter 8), sets how often the display is updated with a power measurement. A lower Refresh Delay will result in more frequent updates of the display, which may be desirable in faster machines, but which may become annoying on other machines.



4.2. Locking and Unlocking

The TECHNA-CHECK® Model 100-L is programmed by the use of four keys located on the front panel. Ordinarily, the unit must be "unlocked" before parameters may be altered from the front panel. To unlock the unit, the MODE key is pressed eight times, until the display shows "On". Both arrow keys are pressed and held for approximately 5 seconds, until the display changes to "Off" and the "Locked" LED starts flashing. (NOTE: The locking feature of the unit can be disabled, as described in the section on "Parameter Mode," parameter 16.) The system can be locked again by pressing the RESET key.

4.3. Primary Monitoring Limits and Timers

Once the system is unlocked, the MODE key is used to switch the LED display from showing power to showing one of the programmable limits or timers. The limits and timers and their programming ranges are listed in Table 1. Green LEDs will illuminate to show which parameter is being viewed and modified. When the green Tr LED is illuminated, along with the condition LED, it indicates that that particular fault delay is being view (i.e., Tr LED and Break LED indicated that the Break Delay is displayed). When a variable has been selected, it may be changed by pressing the arrow keys. Holding an arrow key pressed for about 5 seconds will cause the value to scroll continuously until the key is released. All values are stored in non-volatile memory, and should not need to be restored in the event of a power failure.

Table 1 - Primary Monitoring Limits and Delays

Mode	Function	Variable		+		Display	Defaults
Power[kW]	kW/kWmax Display			Pe	Max Peak	kW%	
Break	Tool-break limit	Off/0.1-100.0%	Decrease		Increase	Off/Break %	50.0%
Blunt	Tool-blunt limit	Off/0.1-100.0%	Decrease		Increase	Off/Blunt %	25.0%
Missing	Tool-missing limit	Off/0.1-100.0%	Decrease		Increase	Off/Missing%	Auto
Ts [Sec]	Start Time	0.0'-99.99 Sec	Decrease		Increase	Star. Delay [Sec]	Off
Tr [Sec]	Tool-break reaction timer	0.0'-99.99 Sec.	Decrease		Increase	Break [Sec.]	0.0' Sec.
Tr [Sec]	Tool-blunt reaction timer	0.0'-99.99 Sec.	Decrease		Increase	Blunt [Sec.]	2.0 Sec.
Tr [Sec]	Tool-missing reaction timer	0.0'-99.99 Sec.	Decrease		Increase	Mising [Sec.]	0.5 Sec.
Locked	Programming lock/unlock	Off/On				Off/On	On
Parameter	Parameter programming	0-20	Decrease		Increase	0-20	0

4.4. Parameter Mode

Parameter Mode is used to set parameters and variables that are usually only changed once. Most of these parameters may also be changed through the use of the TMSMON software package. To access Parameter Mode, the unit must first be unlocked. Then the MODE key is pressed until the red LED next to "Parameter" is lit. The unit will display the Parameter Number. The Parameter Number may be changed by pressing the arrow keys until the desired Parameter Number is displayed. Once the Parameter Number has been selected, pressing the MODE key will display the value currently programmed for that parameter. Pressing the arrow keys will enter different values for the parameter, as listed below. Pressing RESET will save the changed value. The unit returns to the Parameter Mode, and further changes may be made to other parameters. Pressing RESET again will terminate the Parameter Mode, or after about 10 seconds without a key being pressed, the unit will reset itself.

All Parameters and their functions are listed in Table 2. Refer to the appropriate sections of this manual for details of their function.

Table 2 - Parameter Descriptions

Parameter	Function
0	No function
1	This parameter may be used to store a user programmable code or number, for example the delivery date or serial number. When the stored value is displayed, it may be changed by pressing and holding both arrow keys for about five seconds, until the first digit starts flashing. The flashing digit may be changed with the arrow keys. The next digit is selected by pressing the MODE key. This parameter cannot be changed from TMSMON.
2	This parameter is factory set with the hardware type. It cannot be changed.
3	This parameter is factory set with the firmware version number. It cannot be changed.
4	Po Averaging: This parameter sets the number of idle power samples to average to calculate idle power.
5	Missing Tool Mode: This parameter can be used to toggle between Missing Tool Modes. 0 = Automatic, 1 = Absolute, 2 = Learn Work.
6	Averaging: This parameter is used to set the number of power measurement samples that are averaged to perform tool monitoring operations.
7	Display Resolution: This parameter sets the number of decimal places shown on the front panel LED display, 1 = 0.1% resolution, 0 = 1.0% resolution.
8	Refresh Delay: This parameter adjusts the delay between updates of the front panel LED display.
9	Debounce Delay: This parameter sets the delay between samples of the input Start Signal from the machine. It is used in applications where mechanical relays are used for this signal. Refer to the section on "Installation Notes."
10	Ta: This parameter limits the length of time that the system will monitor for Tool Break or Blunt Tool conditions.
11	Tw: This parameter limits the length of time that the system will monitor for Missing Tool conditions.
12	Blunt Counter: This parameter sets the number of consecutive Blunt Tool faults which must be encountered before the Blunt Tool fault output is activated.
13	Analog Zoom P1Max: Establishes the upper limit of the analog zoom. Refer to the section on "Analog Zoom."
14	Analog Zoom P1Min: Establishes the lower limit of the analog zoom. Refer to the section on "Analog Zoom."
15	Current Range: Establishes the scaling of the input power measurements. Refer to the section on "Analog Zoom."
16	<p>16 Lock Enable/Disable: This parameter defines the lock mode, and cannot be changed from TMSMON. (The system also cannot be unlocked from TMSMON.)</p> <p>0 = Lock enabled and valid for all parameters, timers, and limits.</p> <p>1 = Lock disabled.</p> <p>2 = Lock enabled for all parameters and timers, but monitoring limits may still be changed.</p>
17	Analog Output: This parameter sets the mode for the Analog output. If it is set to "AnA" (analog) the analog output port will output a current signal of 4 to 20 mA which is proportional to the power consumption. If it is set to "cnt" (counter) then the analog output will give a 24 VDC signal every time a good part is monitored. Refer to the section on "Installation Notes."
18	Blunt Mode: This parameter sets the Blunt Mode. 0 = Peak Mode, 1 = Work Mode, 2 = Learn Peak, 3 = Learn Work.
19	Blunt Alarm Mode: When monitoring for Blunt Tools in the Peak Mode, this parameter determines when the fault signal will be sent to the machine. 0 = End of machine cycle, 1 = Immediately upon detection.
20	Break Mode: This parameter sets the Break Mode. 0 = Absolute Peak, 1 = Learn Peak.
21	PoMin: This parameter sets the minimum value of idle power (Po) for Idle Power Monitoring.

22	PoMax: This parameter sets the maximum value of idle power (Po) for Idle Power Monitoring.
----	---

5. Installation Notes

5.1. Mechanical Mounting

The TECHNA-CHECK® Model 100-L mounts simply through the electrical cabinet. To install the unit, a 66 mm by 66 mm (2.6 inches by 2.6 inches) square hole should be cut in the cabinet. The unit also requires at least 150 mm (6 inches) of clearance behind.

5.2. Electrical Connection

5.2.1. Power

Electrical connections to the TECHNA-CHECK® Model 100-L are as shown in Figure 11. The current measurement input on the unit is rated for motors with full load ratings up to 10 A. For motors with higher current ratings, an external current transformer must be used. In machines which use a variable speed drive, the system is installed on the line side of the drive.

In some applications, it may not be desirable to run motor wiring to the enclosure door. In these cases, a 120 V, 3 phase TECHNA-CHECK® Model 100-L may be used, with an appropriately rated current transformer for the current input, and an "open delta" arrangement of voltage transformers on the voltage inputs. A wiring diagram for this situation is shown in Figure 12.

5.2.2. Control Inputs

All inputs to the system are standard 24 VDC PLC inputs. In cases where relay logic is used to signal these inputs, it may be necessary to set a **Debounce Delay** (Parameter 9), which will allow the system to ignore any bouncing of mechanical relay contacts.

5.2.3. Control Outputs

Fault conditions are signaled to the machine by two sets of relay contacts. In typical applications, the Break/Missing relay is wired to cause an immediate retraction of the machine head, and the Blunt relay is wired to allow the machine to complete its current cycle before stopping the machine. Because the outputs are relays, they will wire into almost any machine control system, whether it uses relay logic or a PLC. It should be noted that the output relays will be open when there is no power to the unit.

5.2.4. Analog Output

The TECHNA-CHECK® Model 100-L also features a programmable **Analog Output** (Parameter 17). This output may be user configured either as an Analog Output or as a Part Counter. When configured as an Analog Output, it will send out a low voltage current signal of 4 to 20 mA, proportional to the instantaneous measured power. This signal may be useful when using an analog data logger or chart recorder. When configured as a Part Counter, the output will give a 24 VDC output pulse every time the unit monitors a part without faulting. This signal may be used to increment a part counter, or to verify proper system operation.

Figure 11 -- Typical Electrical Installation

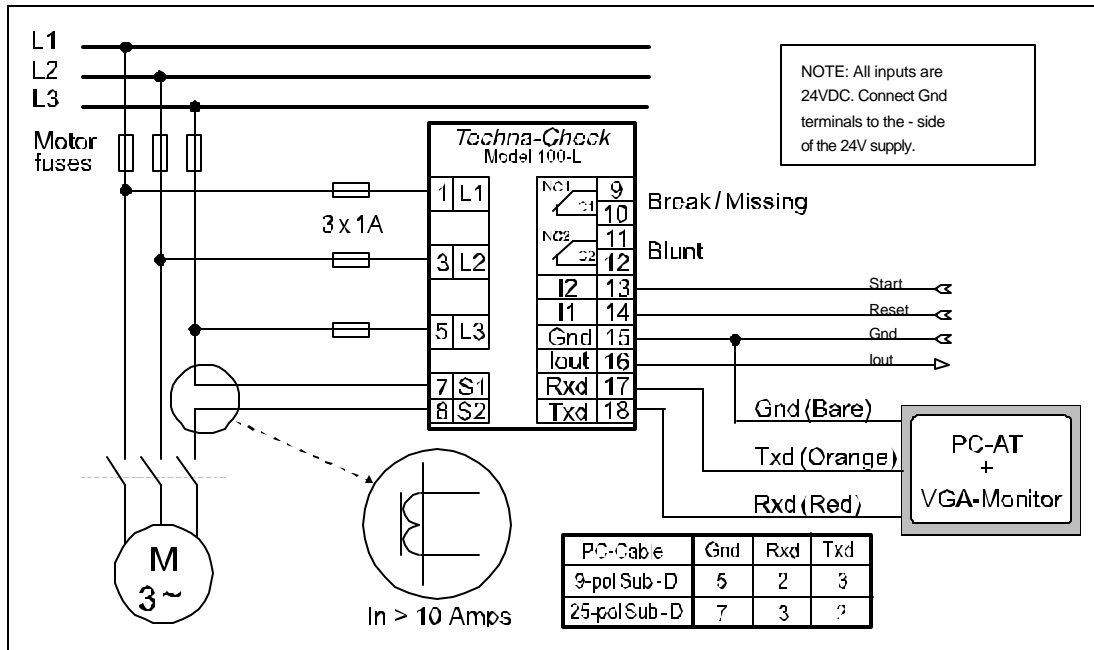
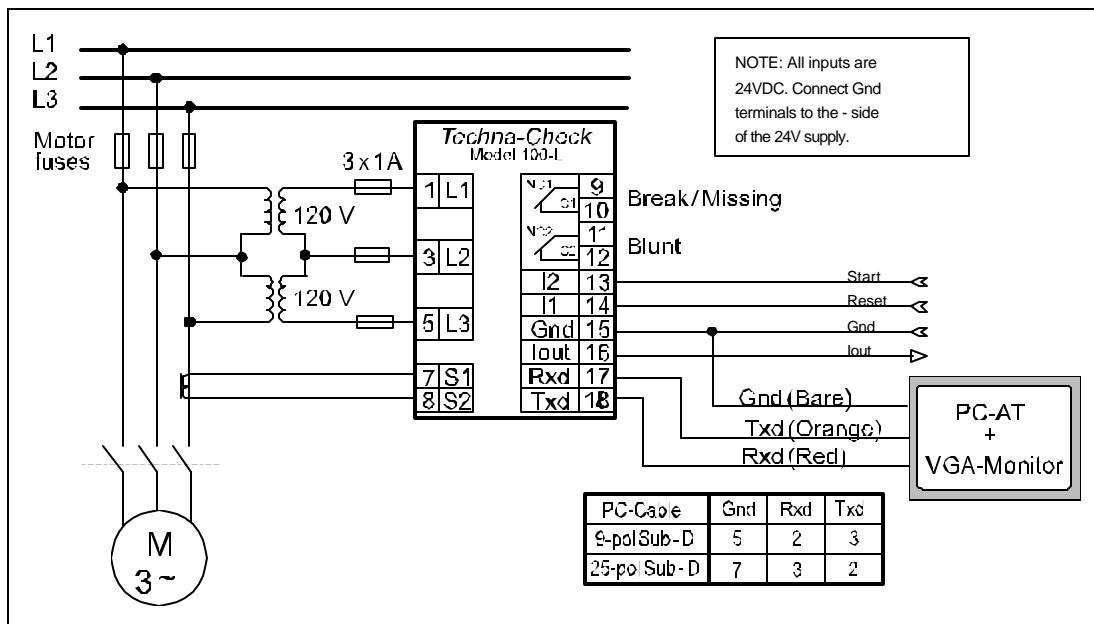

Figure 12 -- No Motor Power to the Unit



6. Ratings and Specifications

6.1. Mechanical

Housing:	Noryl DIN 43700, 72mm x 72mm x 141mm
Mounting:	Panel Mount, 66mm x 66mm square cutout from electrical enclosure
Environmental:	IP55 front, IP20 back
Ambient Temp.:	-15 to +50 C
Weight:	Approximately 500g (1 lb.)

6.2. Electrical

Supply Voltage:	Unit specific, versions available for any standard North American or European voltage, single or three phase
Current:	10 A max on internal sensor
Power Factor Range:	0 - 1 Inductive
Frequency:	50/60 Hz
Power Consumption:	Supplied from measured voltage, 3VA
Relay Outputs:	250 VAC max, 5 A max, Normally Closed, electrically isolated
Analog Output:	4 - 20 mA, 0 - 400 ohm, electrically isolated (Analog Output mode), or 24 VDC, 20 mA, electrically isolated (Part Counter mode)