

# **BK MIKRO 8 SB**

---

Control System for Tool Breakage and Object Monitoring  
with Serial Interface

Operating Instructions  
Issue 1.00 dated 15.5.2006



553 S. Industrial Dr. Hartland, WI 53029 Phone 262-367-8665 Fax 262-367-0208  
web-site [www.techna-tool.com](http://www.techna-tool.com) email [techtool@techna-tool.com](mailto:techtool@techna-tool.com)



## General Notice

### Safety guidelines

These operating instructions contain notices which you should observe to ensure your own personal safety, as well as to protect the product and connected equipment. These notices are highlighted in the manual by a warning triangle and are marked as follows according to the level of danger:



#### Immediate danger

to life and limb of personnel and others.  
Non-compliance may cause death or serious (crippling) injury.



#### Hazardous situation

to life and limb of personnel and others.  
Non-compliance may cause death or serious injury.



#### Potentially hazardous situation

Non-compliance may cause slight injury;  
possible damage to property.



#### Notes on correct handling

Non-compliance may cause damage to the product  
and/or damage to parts/items in the vicinity.



#### Environmental protection

Non-compliance may have an impact on the environment.

### Intended use



BK MIKRO is a control system suitable for tool as well as for object and free space monitoring applications. It may only be used for the applications described in the technical documents, and only in connection with devices or components from other manufacturers which have been approved or recommended by us.

This product can only function correctly and safely if it is transported, stored, set up, and installed correctly, and operated and maintained as recommended.

**Qualification of personnel**

Only qualified personnel may carry out the following activities on the control system: installation, commissioning, operation, maintenance.

Qualified persons in accordance with the safety guidelines are defined as persons who are authorized to commission, to ground, and to tag circuits, equipment, and systems in accordance with established safety practices and standards.

**Disclaimer of liability**

We have checked the contents of this document for agreement with the hardware and software described. Since deviations cannot be precluded entirely, we cannot guarantee full agreement. However, the data in this manual are reviewed regularly and any necessary corrections included in subsequent editions. Suggestions for improvement are welcomed.

**EEC directive EMC 89/336/EEC**

The following applies to BK MIKRO control system:



Products which carry the CE symbol meet the requirements of the EEC directive 89/336/EEC on electromagnetic compatibility.

The EEC declarations of conformity and the related documentation will be maintained at the following address for inspection by the responsible officials in accordance with article 10(1) of the above stated EEC directive:

MSC Tuttlingen GmbH  
Rudolf-Diesel-Straße 17  
78532 Tuttlingen

**Areas of use**

Control systems of the BK MIKRO series meet the applicable, harmonized, European standards for the respective area of applications.

**Fitting conditions**

The fitting conditions and safety notes in the operating instructions must be adhered to when commissioning and operating the devices.

**Copyright**

These operating instructions are intended for the operator and the operator's personnel only. This document and its contents may not be disclosed to third parties, either in full or in part, by reproduction, transmission or any other means without express written authority.

Non-compliance may lead to prosecution under criminal law.

**Contents**

**1 Characteristics .....3**

**2 System Components .....4**

2.1 Control unit.....4

2.1.1 Technical data .....5

2.1.2 Connection terminals .....6

2.1.3 Serial Interface: "BK Diagnostic".....8

2.1.4 LEDs to indicate status information .....9

2.1.5 Optional function: internal DIP switches .....10

2.2 Scanner.....11

2.2.1 Characteristic properties .....11

2.2.2 Technical data scanner BK MIKRO 8A .....12

**3 Functionality .....13**

3.1 Operating mode.....13

3.2 "Scanning" cycles .....13

3.3 "Teach" via the input .....14

3.4 "Teach" with "BK Diagnostic" .....14

3.5 Construction .....15

3.5.1 Parameter.....16

3.6 Error Description .....17

**4 Installation Notes .....18**

4.1 Mounting bracket.....18

4.2 Interference prevention .....18

**5 Ordering Information .....19**

**Table of Figures/Tables**

Fig. 2-1:	Control unit – front view with connections.....	4
Fig. 2-2:	Control unit – dimensions .....	5
Fig. 2-3:	Serial interface "BK Diagnostic" .....	8
Fig. 2-4:	Null modem cable.....	8
Fig. 2-5:	Light-emitting diodes.....	9
Fig. 2-6:	DIP switch S1 .....	10
Fig. 2-7:	4 clips .....	10
Fig. 2-8:	Scanner.....	12
Fig. 3-1:	"Start" cycles.....	13
Fig. 3-2:	Construction of a typical BK MIKRO 8 SB system.....	15
Tab. 3-3:	Parameter list .....	16
Fig. 4-1:	Mounting bracket.....	18

**Purpose**

These operating instructions are part of the documentation of the BK MIKRO 8 SB. They provide service personnel and system advisors with the information required to install, commission, operate and maintain the BK MIKRO 8 SB.

© Copyright MSC Tuttlingen GmbH, 78532 Tuttlingen, 2005

These operating instructions are available as article no. **68 36 248**.

Subject to change without notice.

## 1 Characteristics

BK MIKRO 8 SB is a control system suitable for tool as well as for object and free space monitoring applications.

The complete BK MIKRO 8 SB system is comprised of:

- a control unit BK MIKRO 8 SB (BK824-128),
- a sensor (scanner) BK MIKRO 8A or BK MIKRO 7A (BK8SC or BK7SC),
- a connection cable BK MIKRO 8.

BK MIKRO 8 SB is based on existing design concepts for tool, object and free space monitoring and can be used universally for different types of monitoring by the integration of multiple functions:

The BK MIKRO 8 SB system utilizes a scanner equipped with a wand and contact plate allowing the system to check various length tools and storing up to 128 different lengths in memory.

With the "Teach" function every tool can be set up with its own tolerance or all tools can be saved and later uploaded using the "BK Diagnostic" software. (see chapter 3.4 "Teach" with "BK Diagnostic").

Each tool number can individually store:

- a tool position,
- a tolerance
- a scanning intensity

Interface to the machine control:

- 2 relay outputs of "O.K." and "K.O."
- 2 opto-decoupled of "Teach" and "Start"
- 7 selection inputs of the tool selection

### Principle of operation

The wand of the scanner checks tools, objects or critical areas of free space during the machining cycles.

The control unit tells the scanner to go to the stored position to check for the tool. The control then outputs the results of either "O.K." or "K.O." to the machine control via the relay outputs.

Galvanically isolated inputs and outputs guarantee a high degree of operational safety and protection against interferences.

### Other features

- Scanning in clockwise (CW) or counter-clockwise (CCW) direction
- Four levels of scanning intensity
- Output relay contacts selectable as normally open or normally closed
- Range of tolerance for "O.K." message is adjustable for each tool.
- Indication of the scanning result by two LEDs "O.K." and "K.O." on the control unit
- Detection of cable breaks
- Inputs and outputs can operate in negative or positive logic

## 2 System Components

### 2.1 Control unit

The BK MIKRO 8 SB control unit consists of:

Power board / Bus board	Control board
Connection: Serial Interface 9 pin Sub-D pin to connect PC Connection: Power supply 24 VDC 4 pin, keyed terminal block Connection: Grounding PE 4 pin, keyed terminal block Connection: Relay outputs "O.K." and "K.O." 4 pin, keyed terminal block	Connection: Scanner 8 pin plug to connect scanner Connection: Inputs (Start, Teach, Selection Inputs) 3 x 4 pin, keyed terminal block Light-emitting diodes Four LEDs to indicate status information

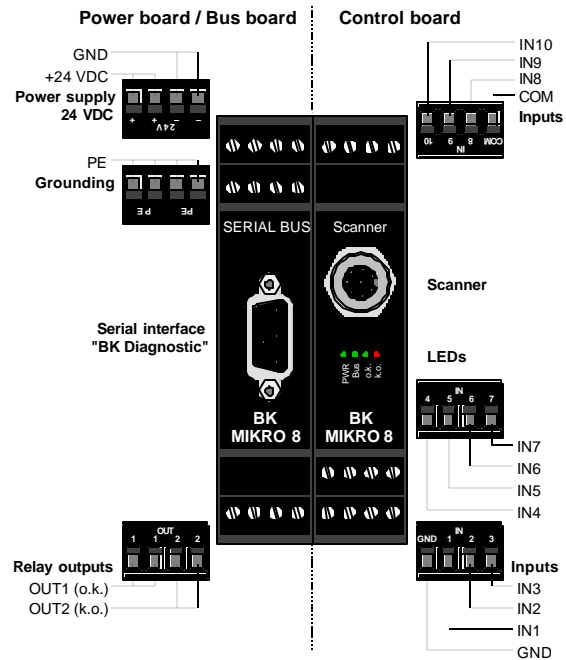


Fig. 2-1: Control unit – front view with connections

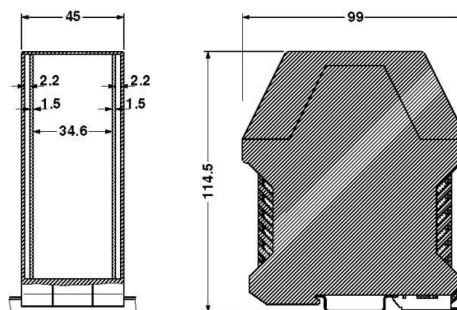


**Note:**

These plugs may only be inserted or removed when the power supply has been disconnected.

**2.1.1 Technical data**

Housing	Insulating material housing, protection class II, built-in unit
Protection type	IP 20
Dimensions (W x H x D)	45 mm x 99 mm x 114.5 mm
Case mountings	Sectional rail, 35 mm, to DIN EN 50022
Power supply voltage	24 VDC $\pm 20\%$ PELV <sup>1)</sup> $I_{max} = 0.4$ A
Power consumption	10 VA max.
Control voltage	24 VDC $\pm 20\%$ PELV <sup>1)</sup>
Inputs - Input current - Pulse duration	Galvanically isolated 6 mA approx. 40 ms min.
Switched outputs	2 x 30 VDC, 2 A max.
Operational life of relay	A minimum of 10 <sup>5</sup> switching cycle by 60 W contact rating; at smaller contact rating service life is increased considerably.
Connections	Plug-in screw terminals for connecting - power supply - ground - relay outputs - control inputs, selection input Scanner, small circular socket, 8 pin Serial interface, Sub-D socket, 9 pin
Climatological conditions	Classification 3K3 under EN 50178
Ambient temperature	0 °C to +50 °C
Storage temperature	-25 °C to +80 °C



General tolerances  
ISO 2768 – mK

Fig. 2-2: Control unit – dimensions

**Note:**

The control unit of BK MIKRO 8 SB is a **built-in unit** !

<sup>1)</sup> PELV = Protected Extra Low Voltage

The voltage applied must meet the requirements for an extra low function potential with safe disconnection (PELV).



2.1.2 Connection terminals

24 V – power supply 24 VDC

	<b>+</b>	Input of 24 VDC supply voltage (2 terminals)
	<b>-</b>	Reference potential of 24 VDC supply voltage (2 terminals)

PE – potential earth

	<b>PE</b>	Connection to earth potential (4 terminals)
--	-----------	--

OUT – relay outputs

	<b>1</b>	<b>O.K. relay</b> Indication of a no fault message (O.K.) (2 terminals)
	<b>2</b>	<b>K.O. relay</b> Indication of a fault message (K.O.) (2 terminals)

The terminals have been designed as dry relay contacts. By internal parameters, they may be configured as either normally closed or normally open.

The contacts have been designed for 24 VDC and, by additional internal circuits, are protected against inductive switch-off peaks of up to 19 W (2 ms).

**Note:**



Relay as normally closed contact:	active	=	open
	inactive	=	closed
Relay as normally open contact:	active	=	closed
	inactive	=	open

When there is **no power** to the unit, the **contacts always** will be **open**.

**Even when using relay as normally closed**, they are open (like the active status) when the power supply is not connected.

**IN – control inputs and selection input**

The inputs can be connected using positive or negative logic.

**Positive logic:**

- Both COM inputs must be tied to GND (0 VDC)
- Inputs (IN 1 – 9) signaled with +24 VDC from machine control
- At low state there is no voltage going to the input terminals

**Negative logic :**

- Both COM inputs must be put on 24 VDC
- Inputs (IN 1 – 9) are given a GND signal (0 VDC)
- At low state there is no GND connection to the input terminals

Unused selection inputs can be left opened. The signal must be a minimum of 40 ms, to register with the unit.

	<p><b>COM</b> Reference potential for inputs IN 1 – 7 Connecting positive logic with GND Connecting negative logic with 24 V</p>
	<p><b>1</b> <b>"Teach" - control input</b> A signal will trigger a learn cycle (the "Teach-in").</p>
	<p><b>2</b> <b>"Start" - control input</b> A signal will trigger a "Start" cycle (the real scanning process).</p>
	<p><b>3</b> <b>Selection input 0</b></p>
	<p><b>4</b> <b>Selection input 1</b></p>
	<p><b>5</b> <b>Selection input 2</b></p>
	<p><b>6</b> <b>Selection input 3</b></p>
	<p><b>7</b> <b>Selection input 4</b></p>
	<p><b>COM</b> Reference potential of the control inputs 8 and 9. If the control inputs 8 and 9 are not needed, this input can be open. Positive logic: GND Negative logic: 24 V</p>
	<p><b>8</b> <b>Selection input 5</b></p>
	<p><b>9</b> <b>Selection input 6</b></p>
	<p><b>10</b> <b>NC – not connected</b></p>

Through the 7 selection inputs 128 different tool positions can be reached. The selection of the tool positions is effected in an binary way, which means that through activating and deactivating the inputs in different combinations all 128 positions can be reached.

e.g. Tool position	Selection inputs						
	S6	S5	S4	S3	S2	S1	S0
0	L	L	L	L	L	L	L
23	L	L	H	L	H	H	H
89	H	L	H	H	L	L	H
127	H	H	H	H	H	H	H

$\overset{\Delta}{L}$  Low (free or 0 V)  
 $\overset{\Delta}{H}$  High (24 V)

**2.1.3 Serial Interface: "BK Diagnostic"**

The serial interface is designed as a RS232 interface. For connection to the pc it is required a null modem cable (crossover cable)

The connector needed is a standard Sub-D plug 9pin.

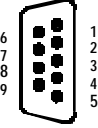
Sub-D socket, 9 pin	Pin	Signal	Function
	1	DCD	unused
	2	RXD	receive data
	3	TXD	send data
	4	DTR	unused
	5	GND	data reference potential
	6	DSR	unused
	7	RTS	unused
	8	CTS	unused
	9	RI	unused

Fig. 2-3: Serial interface "BK Diagnostic"

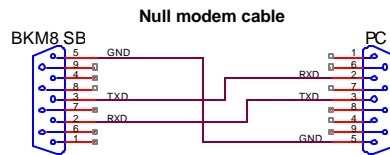


Fig. 2-4: Null modem cable

**2.1.4 LEDs to indicate status information**

Four light-emitting diodes (LEDs) on the front panel of the BK MIKRO 8 SB control board are used to indicate status information.

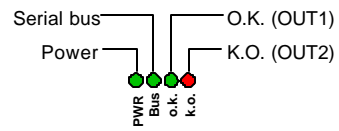


Fig. 2-5: Light-emitting diodes

LED	Color	Designation	Function	Status
Bus	green	Serial Bus (RDY)	Data transmission (RUN)	flashing
			Non bus operation	out
PWR	green	Power	Power supply 24 VDC	on
O.K	green	O.K. (OUT1)	Scanning "O.K."	on
K.O.	red	K.O. (OUT2)	Scanning "K.O."	on

**2.1.5 Optional function: internal DIP switches**

Basic parameters can be set through the internal DIP switches. These parameters can also be set via the software, which is recommended.

When DIP switch 8 is turned on, the parameters that were stored via the software are overwritten by the DIP switch settings. The way the unit functions is now controlled only by the way the DIP switches are set.

The serial interface is also disconnected.

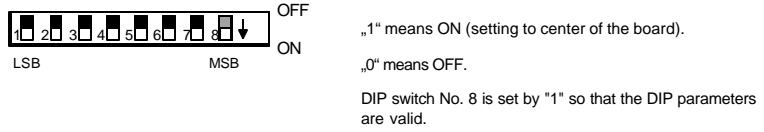


Fig. 2-6: DIP switch S1

DIP switch	Significance	Comment
1	Direction of scanner	0: clockwise 1: counter clockwise
3* and 2**	Scanning intensity	0*0**: ultra – low (only for wand without scanning plate!) 0*1**: low 1*0**: medium 1*1**: high
4	Scanner selection	0: BKM8A 1: TK7A
8	Parameter selection	0: internal parameter and serial bus active 1: DIP switch active
5, 6, 7	Not connected	Possible future changes



**Note:**

During the opening of the housing, all plugs must be removed.

Carefully depress the four clips under the Phoenix connectors upon opening the unit to avoid damage!

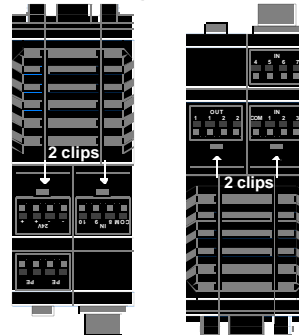


Fig. 2-7: 4 clips

## 2.2 Scanner

### 2.2.1 Characteristic properties

The scanner housing is cylindrical and smooth, thus permitting easy installation (e.g. by using the mounting bracket). The scanner is designed for easy access for servicing and changing the wand. Aligning the scanner is easy and requires no additional instruments or aids.

**The TK8A (BK8SC) scanner offers two special features:**

- Scanning wands are available in lengths up to 380 mm  
This allows greater distances between the scanner and tools or objects that it is checking.
- Scanning plate at the scanning wand  
This makes it possible to use the scanner directly at the tool magazine to make positive contact with the tool's tip.

The TK8A (BK8SC) scanner has a mechanical backstop that limits the rotary movement of the wand.

Using scanner TK8A (BK8SC) with a different control unit than BK MIKRO 8 SB may damage the scanner and control unit.

#### Scanner TK7A (BK8SC)

Optionally it is possible to use the scanner BK MIKRO 7A (BK7SC) with the control unit BK MIKRO 8 SB.

For this, either DIP switch 4 must be switched to 1 (BKM7A TK) and (no bus operation) the DIP switcher 8 to 1 (more details in chapter 2.1.5 "Optional Function: Internal DIP switches") or in parameter menu "BK Diagnostic" must be switched to TK7A.

The TK7A is designed for side scanning operation, therefore shorter wands (up to 165 mm) without scanning plate are used.

Differences between scanners

Scanner	Wand length	Time period of scanning operation 180°	Resolution
TK8A (BK8SC)	Up to 380mm with plate	Ca 1.3 s	+ 0.1°
TK7A (BK7SC)	Up to 165 mm without plate	Ca 0.5 s	+ 0.5°



**Note:**

**Wrong scanner parameters lead to wrong measurement results.**



**Note:**

**The wand is a wearing part.**

**Due to the injury hazard, users should exercise particular caution within any BK MIKRO rotating area.**

2.2.2 Technical data scanner BK MIKRO 8A (BK8SC)

Housing	Anodized aluminum
Protection type	IP 67
Wand length	380 mm, with scanning plate 80 mm x 15 mm, 284 mm, with scanning plate 65 mm x 15 mm, exchangeable wand
Scanning angle	300° max. (with backstop)
Control unit connection	Small circular connector, M12x1, 8 pin
Ambient temperature	0 °C to +80 °C
Storage temperature	-25 °C to +85 °C
Scanning cycles	> 5 million at minimum scanning intensity
Tightening torque of the socket head screw M3 at the wand holder	ca. 1.3 Nm

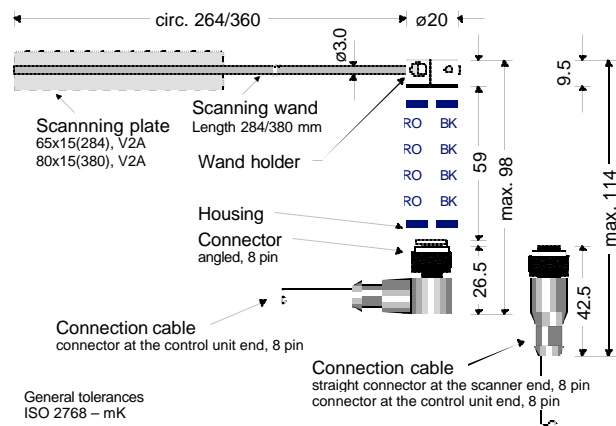


Fig. 2-8: Scanner

### 3 Functionality

#### 3.1 Operating mode

In the control unit of the BK MIKRO 8 SB each of these parameters is stored individually for:

- an angle
- a tolerance
- a scanning intensity

#### 3.2 "Scanning" cycles

The tool number that you would like to check needs to be selected with the correct binary pattern, then the "start" impulse is applied.

The wand will then begin the scanning process.

If the scanning wand contacts the object within the monitoring range, an "O.K." message is outputted.

If the scanning wand stops before the monitoring range or exceeds the range, an "K.O." message is outputted.

The monitoring range begins at "tool angle / -tolerance" and ends at "tool angle / +tolerance".

##### Example:

Tool angle: 100° / tolerance of 3° → Monitoring range: at 97° up to 103°.

The scanning wand moves with high speed and slows down to scan the monitoring range with reduced speed and strength.

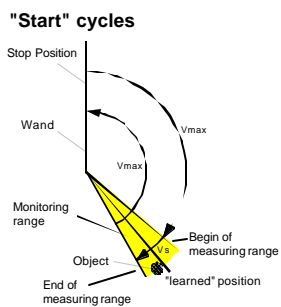


Fig. 3-1: "Start" cycles

Monitoring range = learned (defaulted) position ± tolerance

$V_{max}$  = max. speed of scanning wand  
 $V_s$  = speed of scanning wand preset by "Scanning intensity"

The scanning intensity determines the strength and speed at which the wand contacts the tool in the monitoring range for the "start"-cycle.

Four setting choices:

- ultra low (only for short wands without scanning plate)
- low
- medium
- high

There are 2 possibilities to program the tool parameters, through the "Teach" input and "BK Diagnostic".

### 3.3 "Teach" via the input

When a control signal (24 VDC) is applied to the "Teach" input the scanner begins its scanning process.

The scanning wand moves until it hits an object. This position is then stored under the tool position (tool number), which was selected using a binary pattern on the inputs IN3-IN9.

The first time you "Teach" a tool number it will use the default parameters for the tolerance and scanning intensity settings.

If you have previously set a specific tolerance or scanning intensity via the software for the tool number you are teaching, it will use the values that you have previously entered.

If the scanning wand does not hit an object at "Teach", it moves a maximum of 300° and then moves back, which will trigger a "K.O." message.

The allowable scanning range in the "Start" and "Teach" cycle is between 8° - 300°. Each tool tolerance may be set from 0.2° up to 25.5°.

### 3.4 "Teach" with "BK Diagnostic"

"BK Diagnostic" is a PC-Software (see chapter 5 "Ordering Information"), which you can use to configure the control unit BK MIKRO 8 SB and program tool parameters.

Further instructions for this are in the "Online help" and installation instructions on the CD-ROM.

### 3.5 Construction

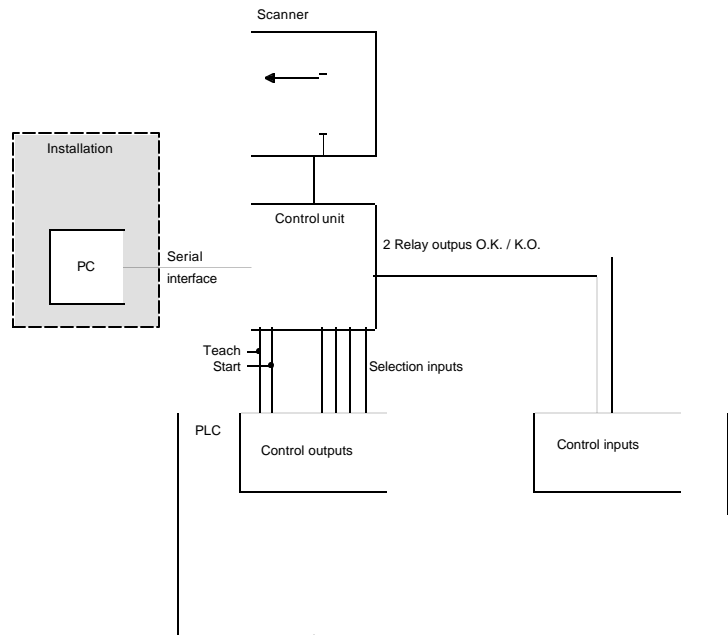


Fig. 3-2: Construction of a typical BK MIKRO 8 SB system

### 3.5.1 Parameter

#### Parameter list

Name	Default	Min.	Max.	Format	Description
Scanning intensity	1	0	3	BK Diagnostic and DIP switch	0 (ultra low) to 3 = high <b>1 = Low</b>
Out1 (O.K.) Relay output	1	0	1	BK Diagnostic	0 = InActive normally closed <b>1 = Active normally open</b>
Out2 (K.O.) Relay output	1	0	1	BK Diagnostic	0 = InActive normally closed <b>1 = Active normally open</b>
Monitoring	1	0	1	BK Diagnostic	0 = Free space <b>1 = Object</b>
Rotation direction	1	0	1	BK Diagnostic and DIP switch	0 = Counter-clockwise <b>1 = Clockwise</b>
Scanner	1	1	2	BK Diagnostic and DIP switch	<b>1 = TK8A</b> <b>2 = TK7A</b>
Return travel monitoring	0	0	1	BK Diagnostic	<b>0: no effect to outputs.</b> 1 : If wand does not come back during return travel, K.O. output will be active.
Power On	1	0	1	BK Diagnostic	0 : Wand will not travel after Power On. <b>1 : Wand will travel to stop position after Power On.</b>
"O.K." / "K.O." in Home position	1	0	1	BK Diagnostic	0: after detecting the object <b>1: after reaching the stop position</b>

Tab. 3-3: Parameter list

Description of the parameters:

- Scanning intensity  
If an object is scanned by the external "Teach" input, this value is used as scanning intensity.
- Out1 and Out2  
Using these parameters relay output 1 (O.K.) and/or relay output 2 (K.O.) can be defined, as it will operate in the "active" state.  
  
After power-up these outputs are always in the set state "normally closed" or "normally open" without a scanning sequence having occurred before.
- Monitoring  
Using this parameter, monitoring mode can be set to object monitoring or free space monitoring.
- When in object monitoring the object will be scanned, and if the object is detected in the defaulted area the "O.K." message will be outputted, or if the object is not detected the "K.O." fault will be outputted.
- When in free space monitoring the system will check whether the predefined area can be scanned by the wand without detecting an obstacle.

When using the monitoring mode in the software the system will not allow a learning cycle.

- **Rotation direction**  
Using this parameter the scanning direction can be changed.  
  
As soon as the parameter is changed, the wand starts to move to the "new stop position" and will set this as the "new" reference position
- **Tolerance range**  
This tolerance is used by external "Teach" input.
- **Scanner**  
This parameter sets the type of scanner. TK8A and TK7A are possible.
- **Return travel monitoring**  
If return travel monitoring is active, the unit will output a "K.O." if the wand does not return to its home reference position.
- **Power On**  
Using this parameter prevents the wand from moving immediately after power-up of the power supply.  
  
The scanning wand moves first from the rest position if a "Teach" or a "Start" is requested.
- **"O.K." / "K.O." in Home-position**  
"O.K." / "K.O." message outputs when the wand returns to the Home-position  
"O.K." / "K.O." message outputs when the wand contacts the object

### 3.6 Error Description

The table shows the possible error messages which can be created by the BK MIKRO 8 SB control unit.

A more detailed error message will be shown with the PC-software "BK-Diagnostic".

Error / Fault	LED Status *	Trouble shooting
"K.O." message of scanner	on	Tool is broken / no tool at this position
Scanner / cable error	on	1. Connection to the scanner is broken 2. Scanner / cable is broken
Selected tool not programmed	flashing	"Teach" an object a tool number
"Teach" in free space monitoring	flashing	"Teach" is not allowed in free- space monitoring
No external "Teach" allowed	flashing	Close the Windows program

\* The "K.O."-relay switches to "on" at every error (for relay active mode, see chapter parameter).

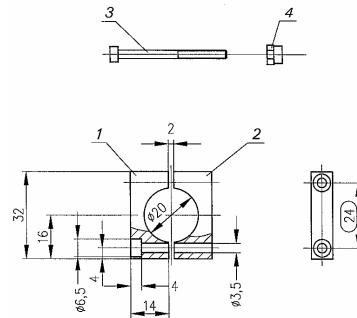
## 4 Installation Notes

### 4.1 Mounting bracket

The standard system contains a mounting bracket for the scanner:

Article no. 61 07 165 (BK7-8MB) contains the following parts:

Designation	Material	Part no.
Mounting bracket	AlCuMgPb, F 38, thickness 8, naturally anodized	1, 2
2 cheese head screws with hexagonal hole M3x40	8.8 zincd	3
2 self-securing nuts M3	8 zincd	4



General tolerances ISO 2768 – mK  
burred edges

Fig. 4-1: Mounting bracket

### 4.2 Interference prevention

All inputs are opto-decoupled and thus maximally protect against interference voltage peaks, as caused, for example, by inductive sources.

Relay outputs are protected by varistors against inductive interference voltage peaks. Depending on the type of load used, further interference suppression measures may be necessary.

To ensure optimum operational safety, suppression measures, if required, must be taken at the source, i.e. directly where interference is caused.

#### Possible additional noise filters:



- RC combination (included in the contactor suppliers' product ranges)
- Varistors
- Diodes

## 5 Ordering Information

---

### COMPLETE SYSTEMS:

**BK8 24 Volt DC System for 128 tools**  
**(with Serial Interface)** **BK824S-128**  
 (Includes BK8SC, BK824-128, BK8C10 and BK7-8MB)

**BK8 24 Volt DC System for 32 tools**  
**(Controlled by Profibus)** **BK824S-PROFI**  
 (Includes BK8SC, BK824, BK8C10 and BK7-8MB)

---

### COMPONENTS:

	<u>Model#</u>	<u>Description</u>
<b><u>Scanner:</u></b>	BK8SC	Scanner (TK8A.xx, 6304237)
<b><u>Controllers:</u></b>	BK824-128	24 Volt DC (6304238)
	BK824-PROFI	24 Volt DC (6304236)
<b><u>Cables:</u></b>	BK8C5	5m length; molded plug connector at scanner and controller
	BK8C10	10m length; molded plug connector at scanner and controller
	BK8C15	15m length; molded plug connector at scanner and controller
<b><u>Bracket:</u></b>	BK7-8MB	Mounting Bracket, 25mm (1") sq.
<b><u>Spare Parts:</u></b>	BKPH8 – with weight	Pin Holder Model 8 – standard Includes 380mm wand w/paddle and counter weight
	BKPH8	Pin Holder Model 8 – includes 380mm wand w/paddle
	BK8WEIGHT	Counter weight for BK8SC
	BKPIN8	380mm scanning wand w/paddle

---

**Delivery:** 1-5 systems normally from stock / 6 or more 2-4 weeks

**BK MIKRO 8 SB**

**Operating Instructions**

**Logbuch**

<b>Ausgabe</b>	<b>Datum</b>	<b>Datei-Name</b>	<b>Charakteristik</b>
1.00	15.05.06	BA_100_e_BK MIKRO 8 SB.doc	Basis: Version 1.00 deutsch

<b>Erstellt</b>	am: 15.05.2006	von: Corina Bader
<b>Geprüft</b>	am: .....	von: .....
<b>Freigegeben</b>	am: .....	von: .....